

## Model SMD-M201

Steel 3V Blades

UL 555S Leakage Class I

### Application

Model SMD-M201 is a leakage rated smoke damper with 3V style blades. The SMD-M201 has been qualified to 10.2 m/s and 1 kPa for operational closure in emergency smoke control situations. Model SMD-M201 may be installed vertically (with blades running horizontally) or horizontally and is rated for airflow and leakage in either direction.

### Ratings

#### UL 555S Leakage Rating

Leakage Class:	I
Operational Rating:	Limits are actuator dependant
Maximum Velocity:	10.2 m/s
Maximum Pressure:	1 kPa
Maximum Temperature:	177°C— Depending on actuator

Construction	Standard	Optional
Frame Material	Galvanized steel	-
Frame Material Thickness	1.5mm (16 ga.)	-
Frame Type	127mm x 25mm (5 in. x 1in.) hat channel	Double Flange
Blade Material	Galvanized steel	-
Blade Material Thickness	1.5mm (16 ga.)	-
Blade Type	3V	-
Linkage	Plated steel out of airstream, concealed in jamb	-
Axle Bearings	Bronze	-
Axle Material	Plated steel	-
Blade Seals	Silicone	-
Jamb Seals	304SS	-

### Size Limitations

W x H	Minimum Size	Maximum Size	
		Single Section	Multi- Section
mm	203 x 152	813 x 1270 or 914 x 1219	3658 x 2540 or 7315 x 1270
Inches	8 x 6	32 x 50 or 36 x 48	144 x 100 or 288 x 50

### Options:

- OCI (Open Closed Indication switches)
- Galvanized steel sleeved
- Actuators (24V, 230V)
- Flanges
- Momentary test switch
- POC retaining angles
- 69°C fusible link (BS476)
- Transitions (R, C)
- Sleeve with integral flange on both sides available

Model SMD-M201 meets the requirements for smoke dampers established by:

**National Fire Protection Association**  
NFPA Standards 92A, 92B, 101 & 105  
**IBC International Building Codes**

**“UL CLASSIFIED (see complete marking on product)”**  
**“UL CLASSIFIED to Canadian safety standards (see complete marking on product)”**  
Standard 555S (Listing #R13447)



Greenheck Kunshan Co. Ltd. and Greenheck Fan Corporation certifies that the model SMD-M201 shown herein is licensed to bear the AMCA Seal. The ratings shown are based on tests and procedures performed in accordance with AMCA Publication 511 and comply with the requirements of the AMCA Certified Ratings Programs. The AMCA Certified Ratings Seal applies to air performance ratings only.

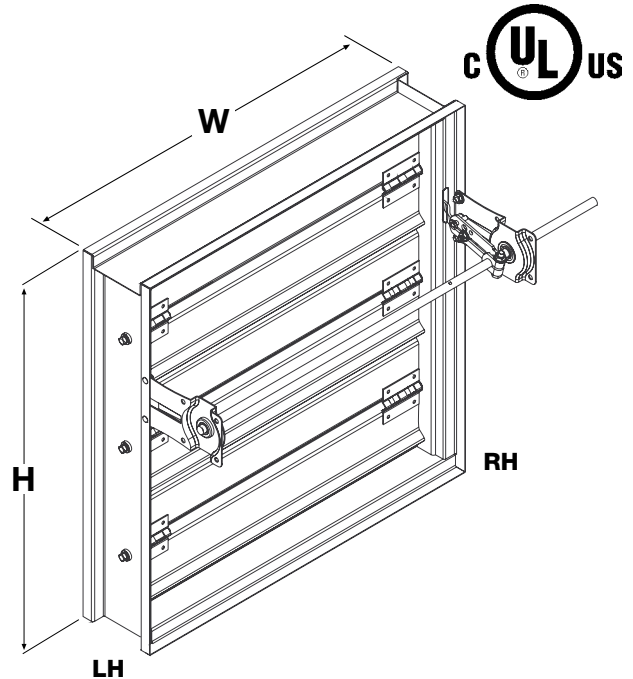

\* W&H dimensions furnished approximately 6mm undersize.  
(Add sleeve thickness for overall sleeved damper dimension)  
Right hand drive is shown. Left hand drive is available upon request.

### Features:

- Frames are constructed with reinforced corners. Low profile head and sill are used on sizes less than 432mm (17 in.) high.
- Blades are reinforced with 3 longitudinal structurally designed vee's.
- Actuators: 24V or 230V

# Pressure Drop Data

# SMD-M201

This pressure drop testing was conducted in accordance with AMCA Standard 500-D using the three configurations shown. All data has been corrected to represent standard air at a density of 1.201 kg/m<sup>3</sup>.

Actual pressure drop found in any HVAC system is a combination of many factors. This pressure drop information along with an analysis of other system influences should be used to estimate actual pressure losses for a damper installed in a given HVAC system.

## AMCA Test Figures

**Figure 5.3** Illustrates a fully ducted damper. This configuration has the lowest pressure drop of the three test configurations because entrance and exit losses are minimized by straight duct runs upstream and downstream of the damper.

**Figure 5.2** Illustrates a ducted damper exhausting air into an open area. This configuration has a lower pressure drop than Figure 5.5 because entrance losses are minimized by a straight duct run upstream of the damper.

**Figure 5.5** Illustrates a plenum mounted damper. This configuration has the highest pressure drop because of extremely high entrance and exit losses due to the sudden changes of area in the system.

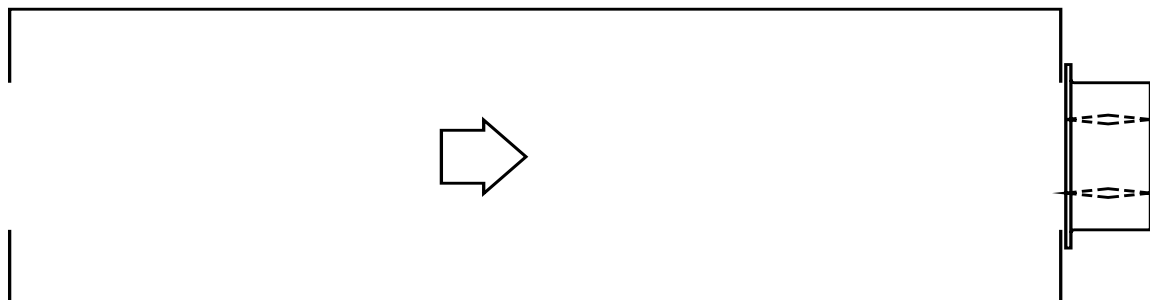
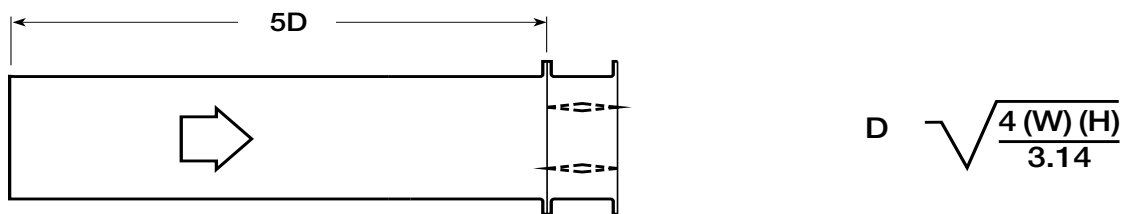
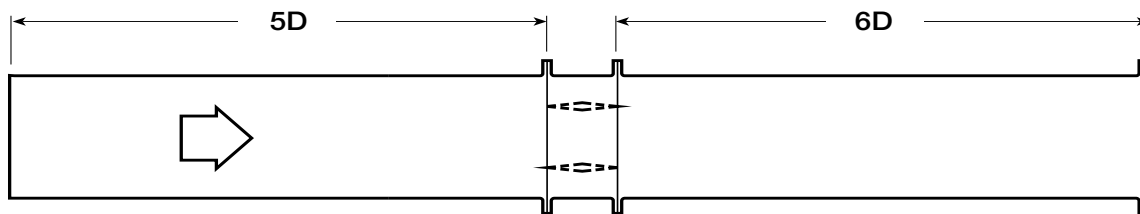

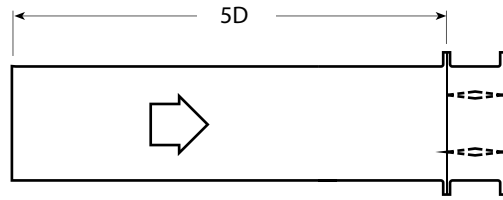
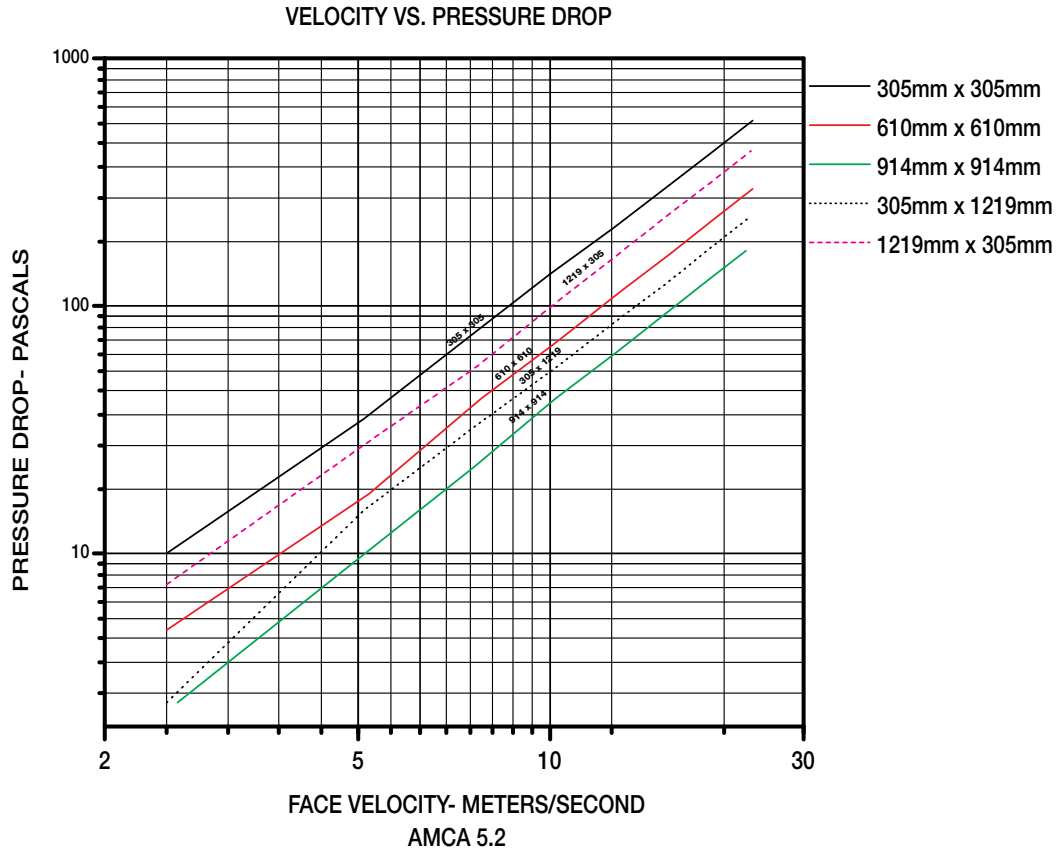

Figure 5.2



305mm x 305mm	
Velocity (m/s)	Pressure Drop (Pa)
2.5	10
5.1	35
7.7	80
10	135
12.6	207
15.5	311
17.8	411
20.8	561

610mm x 610mm	
Velocity (m/s)	Pressure Drop (Pa)
2.5	5
5.2	17
7.8	42
10.3	72
12.9	115
15.4	162
18.1	224
20.8	297

914mm x 914mm	
Velocity (m/s)	Pressure Drop (Pa)
2.6	3
5.1	10
7.6	22
10.2	42
12.7	65
15.3	95
17.7	127
20.3	167

305mm x 1219mm	
Velocity (m/s)	Pressure Drop (Pa)
2.5	3
5.1	15
7.6	32
10.3	57
12.9	90
15.3	125
18	174
20.5	227

1219mm x 305mm	
Velocity (m/s)	Pressure Drop (Pa)
2.5	8
5.1	27
7.7	57
10.3	105
12.9	164
15.6	242
17.9	316
20.7	424



Greenheck Kunshan Co. Ltd. and Greenheck Fan Corporation certifies that the model SMD-M201 shown herein is licensed to bear the AMCA Seal. The ratings shown are based on tests and procedures performed in accordance with AMCA Publication 511 and comply with the requirements of the AMCA Certified Ratings Programs. The AMCA Certified Ratings Seal applies to air performance ratings only.

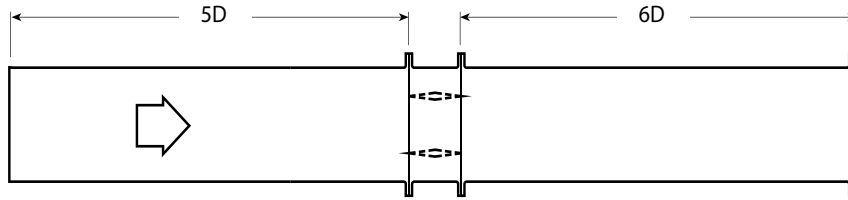
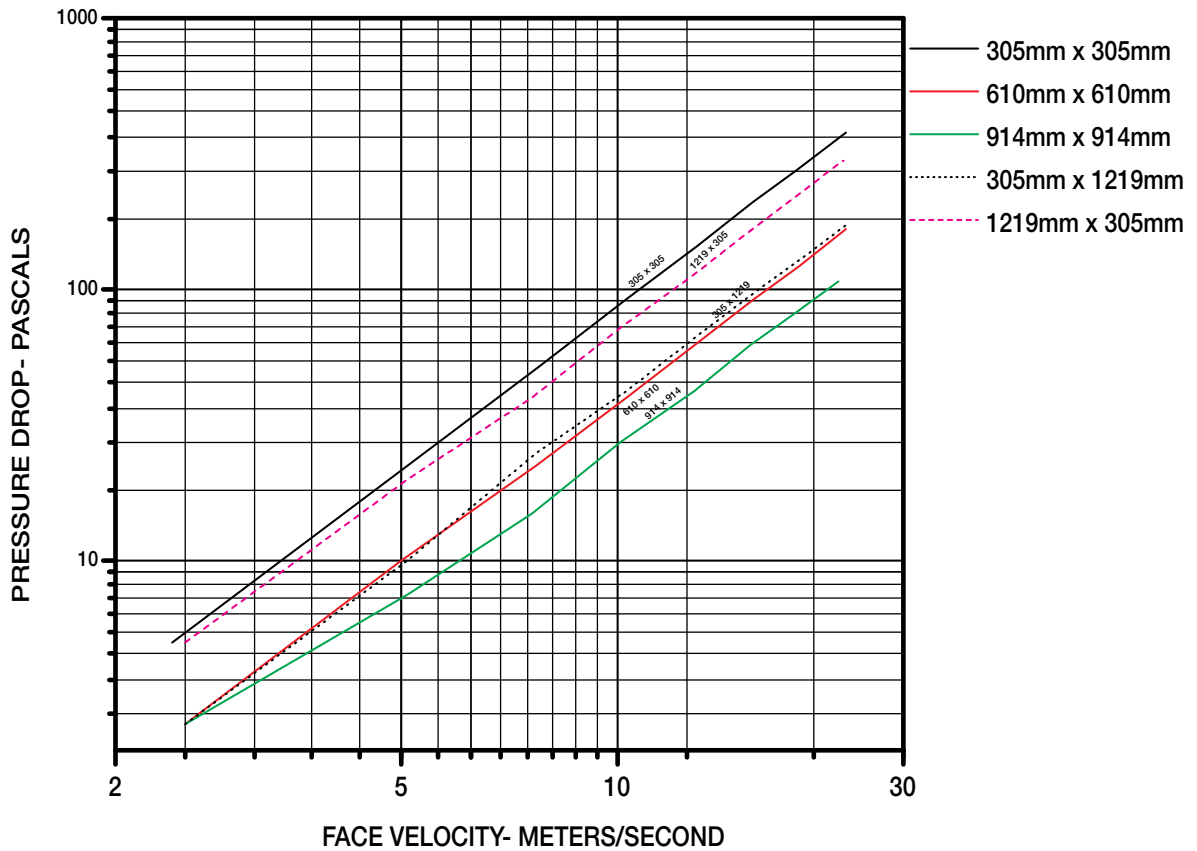

Figure 5.3

### VELOCITY VS. PRESSURE DROP



### AMCA 5.3

305mm x 305mm	
Velocity (m/s)	Pressure Drop (Pa)
2.4	5
5.1	22
7.8	52
10.3	92
12.9	145
15.4	209
17.7	274
20.8	379

610mm x 610mm	
Velocity (m/s)	Pressure Drop (Pa)
2.5	3
5	10
7.7	22
10.3	40
12.8	62
15.5	92
17.9	122
20.8	167

914mm x 914mm	
Velocity (m/s)	Pressure Drop (Pa)
2.5	3
5.1	8
7.6	15
10.1	27
12.8	42
15.3	62
17.7	82
20.3	107

305mm x 1219mm	
Velocity (m/s)	Pressure Drop (Pa)
2.5	3
5.1	10
7.7	25
10.3	42
12.9	67
15.7	100
18.7	140
20.9	174

1219mm x 305mm	
Velocity (m/s)	Pressure Drop (Pa)
2.5	5
5.1	20
7.6	40
10.1	72
12.7	112
15.3	164
18	227
20.6	299



Greenheck Kunshan Co. Ltd. and Greenheck Fan Corporation certifies that the model SMD-M201 shown herein is licensed to bear the AMCA Seal. The ratings shown are based on tests and procedures performed in accordance with AMCA Publication 511 and comply with the requirements of the AMCA Certified Ratings Programs. The AMCA Certified Ratings Seal applies to air performance ratings only.

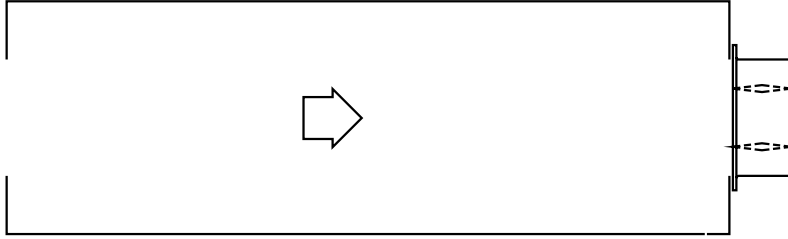

VELOCITY VS. PRESSURE DROP

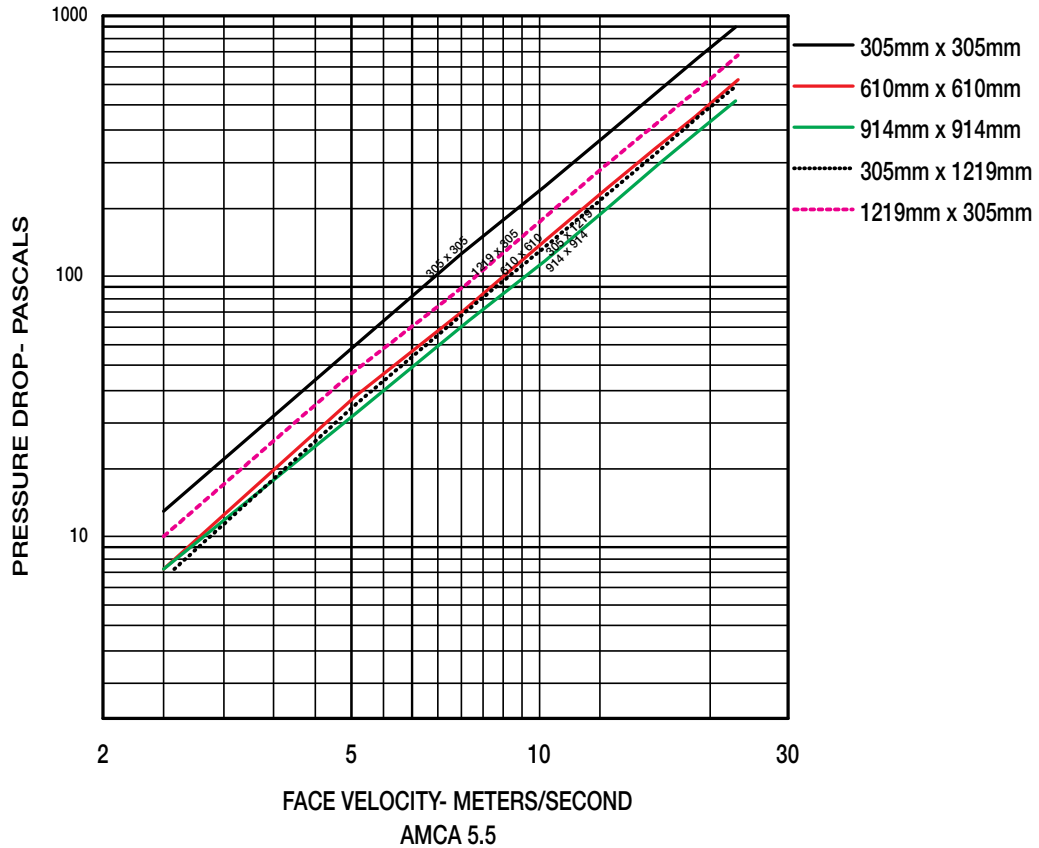

305mm x 305mm	
Velocity (m/s)	Pressure Drop (Pa)
2.5	16
5	55
7.5	122
10.2	222
12.7	349
15.4	508
17.9	688
20.6	907

610mm x 610mm	
Velocity (m/s)	Pressure Drop (Pa)
2.5	8
5	35
7.6	75
10.3	140
12.8	217
15.3	309
17.7	409
20.8	568

914mm x 914mm	
Velocity (m/s)	Pressure Drop (Pa)
2.5	8
5.1	30
7.7	67
10.2	115
12.9	184
15.5	269
18.1	354
20.6	471

305mm x 1219mm	
Velocity (m/s)	Pressure Drop (Pa)
2.6	8
5.1	32
7.7	75
10.2	130
12.7	202
15.5	301
18.1	416
20.6	536

1219mm x 305mm	
Velocity (m/s)	Pressure Drop (Pa)
2.5	1
5	42
7.7	95
10.3	172
12.7	264
15.3	381
17.9	521
20.8	707



Greenheck Kunshan Co. Ltd. and Greenheck Fan Corporation certifies that the model SMD-M201 shown herein is licensed to bear the AMCA Seal. The ratings shown are based on tests and procedures performed in accordance with AMCA Publication 511 and comply with the requirements of the AMCA Certified Ratings Programs. The AMCA Certified Ratings Seal applies to air performance ratings only.

# Damper Sizing Information

The Single Section figure below shows the maximum damper section size.

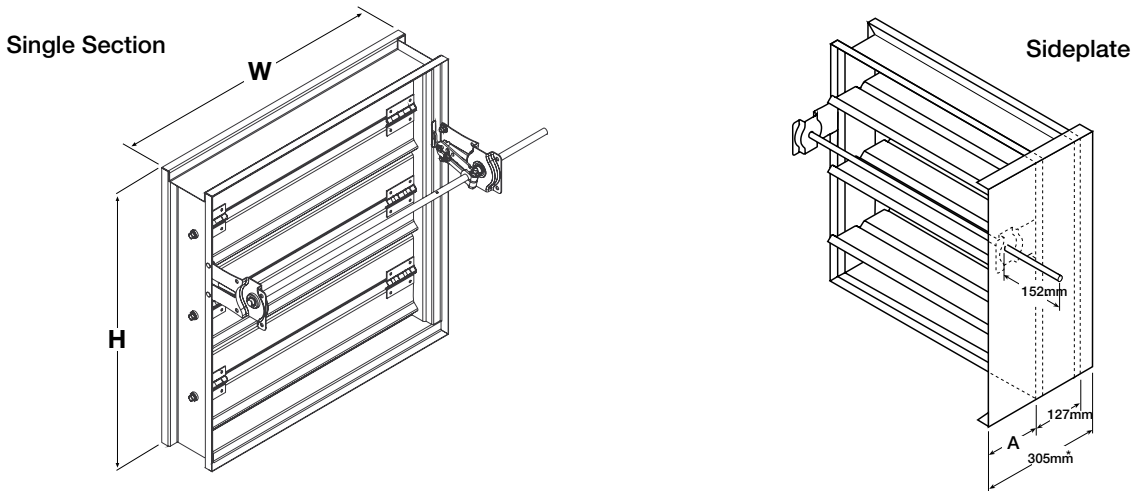

## Damper Sideplate and Sleeve Dimensional Data

The drawings above and below illustrate the factory standard sideplate and sleeve mountings for the SMD-M201. The standard "A" dimensions listed in the table provide adequate space for the mounting of actuators and controls.

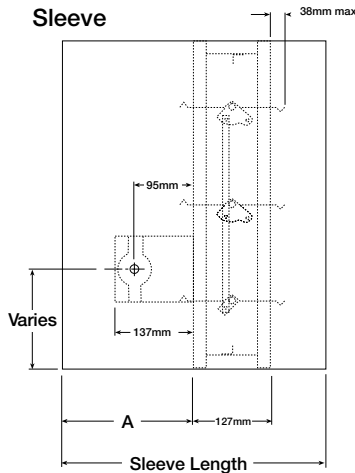

	"A" Dimension*			
	Standard	Minimum	Maximum	Sideplate
All Dampers <sup>1</sup>	183mm	137mm	406mm	157mm
When H is < 279 mm w/OCI, RRL, or TOR	305mm	305mm	406mm	305mm
When H is > 279mm w/OCI, RRL, or TOR	183mm	183mm	406mm	157mm

<sup>1</sup>All dampers w/o OCI, RRL, or TOR.

\*Consult factory for any other requests.

Note: Entire damper frame is not required to be installed within the wall. The damper blades, when closed, should be contained in the wall.

## Specifications

Smoke Dampers meeting the following specifications shall be furnished and installed where shown on plans and/or as described in schedules. Dampers shall meet the requirements of the latest edition of NFPA 92A, 92B, 101 & 105.

Dampers shall be tested, rated and labeled in accordance with the latest edition of UL Standard 555S. Dampers shall be UL labeled for use in dynamic systems. The damper shall have a dynamic closure airflow rating equal to or greater than the airflow at the damper's installed location and a dynamic closure pressure rating of 1 kPa.

Dampers shall have a UL 555S Leakage rating of Class I and a Temperature rating of 121°C. Dampers shall have a UL 555S operational airflow rating equal to or greater than the airflow at its installed location and an operational pressure rating of 996 Pa. Damper actuators shall be factory mounted and qualified for use with the damper in accordance with UL 555S. Damper actuators shall be (specifier select one of the following) electric type for 120 (24 or 230) volt operation or pneumatic type for 20 psi or 25 psi minimum operation (depending on actuator). Manufacturers submittal data shall indicate actuator space requirements around the damper.

All UL 555S Dynamic Closure Ratings, Operational Ratings and Leakage Ratings shall be qualified for airflow and pressure in either

direction through the damper. UL ratings shall allow for mounting damper vertically (with blades running horizontal) or horizontally.

The Damper Manufacturers submittal data shall certify all air performance pressure drop data is licensed in accordance with the AMCA Certified Ratings Program for Test Figures 5.2, 5.3 and 5.5. Damper air performance data shall be developed in accordance with the latest edition of AMCA Standard 500-D. Dampers shall be labeled with the AMCA Air Performance Seal.

Damper blades shall be 1.5mm galvanized steel 3V type with three longitudinal grooves for reinforcement. Blades shall be completely symmetrical relative to their axle pivot point, presenting identical resistance to airflow and operation in either direction through the damper (blades that are non-symmetrical relative to their axle pivot point or utilize blade stops larger than 13mm are unacceptable).

Damper frames shall be galvanized steel formed into a structural hat channel shape with reinforced corners. Bearings shall be sintered bronze sleeve type rotating in extruded holes in the damper frame. Jamb seals shall be stainless steel compression type.

Basis of design is Greenheck Model SMD-M201.



Greenheck Kunshan Co Ltd.

No. 1188 Pengqing Road • Huaqiao Town • Kunshan, Jiangsu China 215332  
Tel: 86.512.5736-6666 • Fax: 86.512.5737-8633

Copyright © 2010 Greenheck Fan Corporation  
SMD-M201 rev. 8 December 2010