

**Combination Fire Smoke Dampers**
**Steel 3V Blades**
**UL 555S Leakage Class I**
**UL 555 1½ Hour Fire Resistance Rating**
**4 Hour Fire Resistance Rating (BS476)**
**Application**

Model FSD-M211 is a combination fire smoke damper with 3V style blades. The FSD-M211 has been qualified to 10.2 m/s and 1 kPa for operation and dynamic closure in emergency fire smoke situations. Model FSD-M211 may be installed vertically (with blades running horizontal) or horizontally and is rated for airflow and leakage in either direction.

Model FSD-M211 has also been tested in accordance with BS476 to 4 hours at Warrington Fire, UK, and is approved for fire partitions of 4 hours or less where British Standards are required.

**Ratings**
**UL 555 Fire Resistance Rating**

Fire Rating: 1½ Hours  
 Dynamic Closure Rating: Actual ratings are size dependant  
 Maximum Velocity: 10.2 m/s  
 Maximum Pressure: 1.5 kPa

**UL 555S Leakage Rating**

Leakage Class: I  
 Operational Rating: Actual ratings are actuator dependant  
 Maximum Velocity: 10.2 m/s  
 Maximum Pressure: 1.5 kPa  
 Max. Temperature: 177°C – Depending on actuator

**BS476 Fire Resistance Rating**

Fire Rating: 4 hours

Construction	Standard	Optional
Frame Material	Galvanized steel	-
Frame Material Thickness	1.5mm (16 ga.)	-
Frame Type	127mm x 25mm (5 in. x 1in.) hat channel	-
Blade Material	Galvanized steel	-
Blade Material Thickness	1.5mm (16 ga.)	-
Blade Type	3V	-
Linkage	Plated steel out of airstream, concealed in jamb	-
Axle Bearings	Bronze	-
Axle Material	Plated steel	-
Blade Seals	Silicone	-
Jamb Seals	304SS	-
Closure Device	RRL	RRL/OCI, TOR, Fusible Link
Closure Temperature	74°C (165°F)	100°C (212°F), 121°C (250°F), 177°C (350°F)

Model FSD-M211 meets the requirements for fire dampers, smoke dampers and combination fire smoke dampers established by:

**National Fire Protection Association**

NFPA Standards 80, 90A, 92A, 92B, 101, & 105

**IBC International Building Codes**
**British Standard BS476**

Tested to 4 hours at Warrington Fire, UK

**“UL CLASSIFIED (see complete marking on product)”**

**“UL CLASSIFIED to Canadian safety standards (see complete marking on product)”**

Standard 555 & 555S (Listing #R13317)



Greenheck Kunshan Co. Ltd. and Greenheck Fan Corporation certifies that the model FSD-M211 shown herein is licensed to bear the AMCA Seal. The ratings shown are based on tests and procedures performed in accordance with AMCA Publication 511 and comply with the requirements of the AMCA Certified Ratings Programs. The AMCA Certified Ratings Seal applies to air performance ratings only.

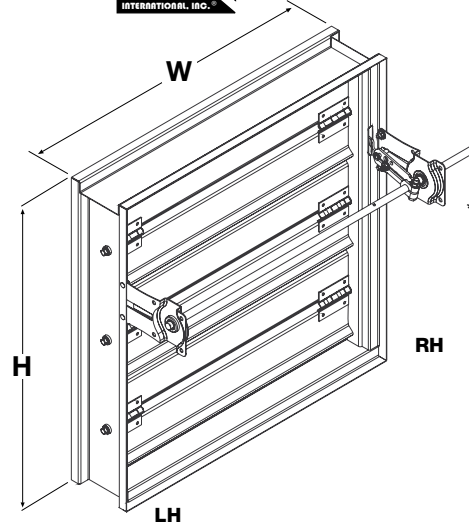

\*W & H dimensions furnished approximately 6mm undersize. (Add sleeve thickness for overall sleeved damper dimension)  
 Right hand drive is shown. Left hand drive is available upon request.

**Features:**

- Frames are constructed with reinforced corners. Low profile head and sill are used on sizes less than 432mm (17 in.) high.
- Blades are reinforced with 3 longitudinal structurally designed vee's.

W x H	Minimum Size	Maximum Size		
		Single Section	Multiple Section	
			Horizontal	Vertical
<b>4 in. wg (1 kPa) pressure</b>				
Inches	8 x 6	32 x 50 or 36 x 48	144 x 96	128 x 100
mm	203 x 152	813 x 1270 or 914 x 1219	3658 x 2438	3251 x 2540
<b>6 in. wg (1.5 kPa) pressure</b>				
Inches	8 x 6	36 x 48	144 x 48	128 x 48
mm	203 x 152	914 x 1219	3658 x 1219	3251 x 1219

## Options available on FSD-M211:

- RRL/OCI (Open Closed Indication switches)
- Actuators (24V, 230V)
- Momentary test switch
- 69°C fusible link (BS476)
- TOR (Temperature Limited Override)
- Flanges
- POC retaining angles
- Transitions (R, C)

## Pressure Drop Data

This pressure drop testing was conducted in accordance with AMCA Standard 500-D using the three configurations shown. All data has been corrected to represent standard air at a density of 1.201 kg/m<sup>3</sup>.

Actual pressure drop found in any HVAC system is a combination of many factors. This pressure drop information along with an analysis of other system influences should be used to estimate actual pressure losses for a damper installed in a given HVAC system.

### AMCA Test Figures

**Figure 5.3** Illustrates a fully ducted damper. This configuration has the lowest pressure drop of the three test configurations because entrance and exit losses are minimized by straight duct runs upstream and downstream of the damper.

**Figure 5.2** Illustrates a ducted damper exhausting air into an open area. This configuration has a lower pressure drop than Figure 5.5 because entrance losses are minimized by a straight duct run upstream of the damper.

**Figure 5.5** Illustrates a plenum mounted damper. This configuration has the highest pressure drop because of extremely high entrance and exit losses due to the sudden changes of area in the system.

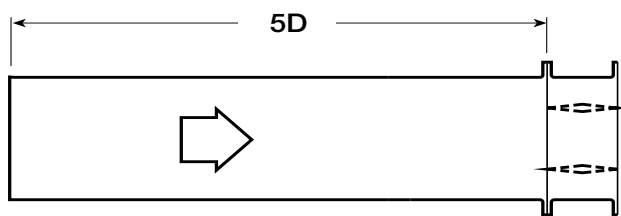
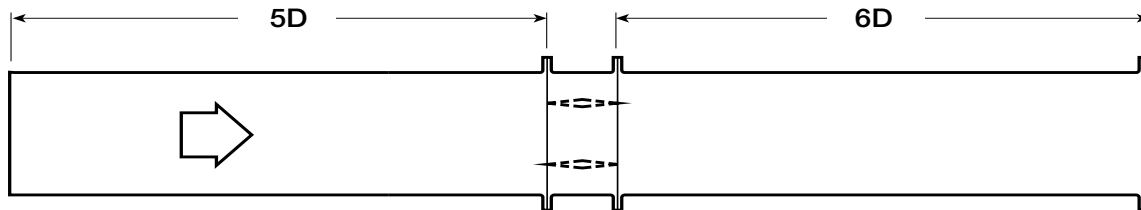

$$D = \sqrt{\frac{4(W)(H)}{3.14}}$$

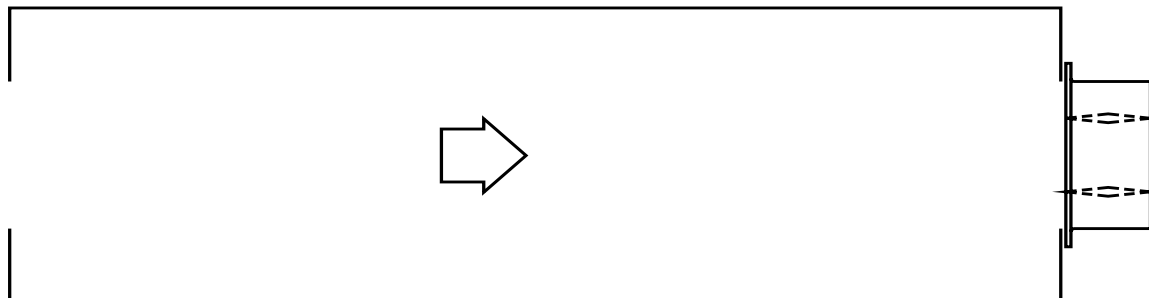

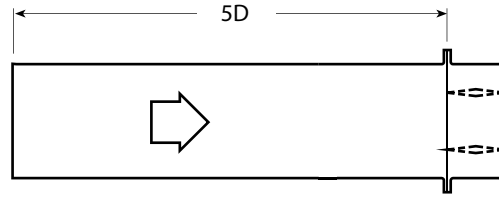
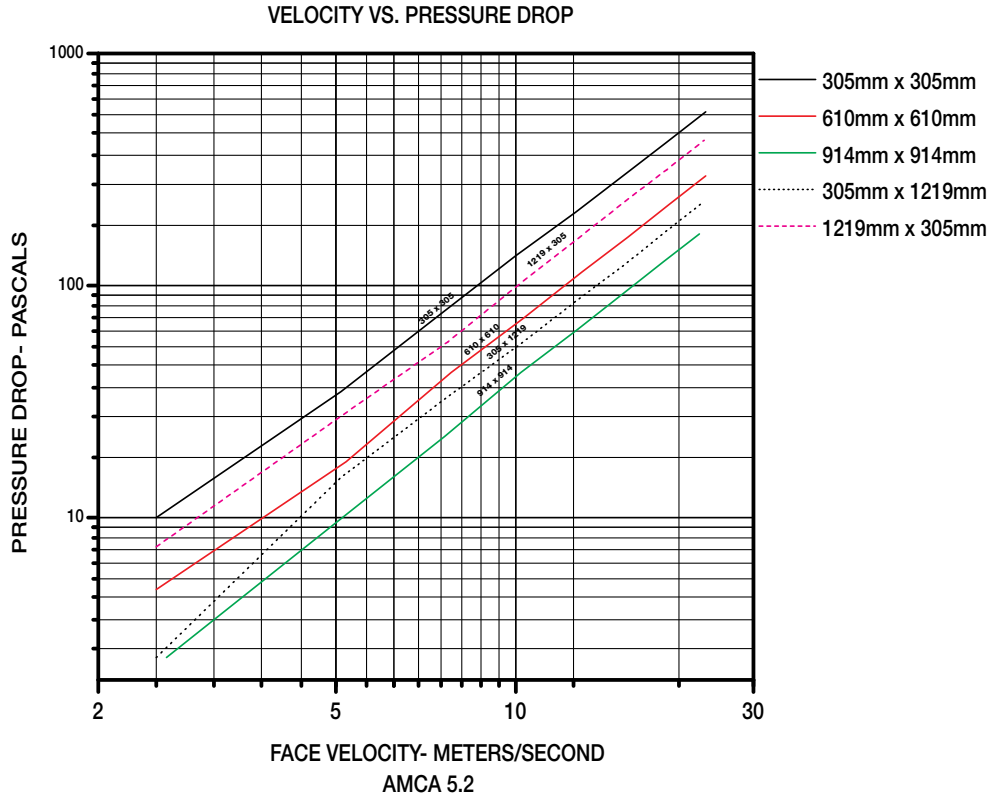

Figure 5.2



305mm x 305mm	
Velocity (m/s)	Pressure Drop (Pa)
2.5	10
5.1	35
7.7	80
10	135
12.6	207
15.5	311
17.8	411
20.8	561

610mm x 610mm	
Velocity (m/s)	Pressure Drop (Pa)
2.5	5
5.2	17
7.8	42
10.3	72
12.9	115
15.4	162
18.1	224
20.8	296

914mm x 914mm	
Velocity (m/s)	Pressure Drop (Pa)
2.6	3
5.1	10
7.6	22
10.2	42
12.7	65
15.3	95
17.7	127
20.3	167

305mm x 1219mm	
Velocity (m/s)	Pressure Drop (Pa)
2.5	3
5.1	15
7.6	32
10.3	57
12.9	90
15.3	125
18	174
20.5	227

1219mm x 305mm	
Velocity (m/s)	Pressure Drop (Pa)
2.5	8
5.1	27
7.7	57
10.3	105
12.9	164
15.6	242
17.9	316
20.7	424



Greenheck Kunshan Co. Ltd. and Greenheck Fan Corporation certifies that the model FSD-M211 shown herein is licensed to bear the AMCA Seal. The ratings shown are based on tests and procedures performed in accordance with AMCA Publication 511 and comply with the requirements of the AMCA Certified Ratings Programs. The AMCA Certified Ratings Seal applies to air performance ratings only.

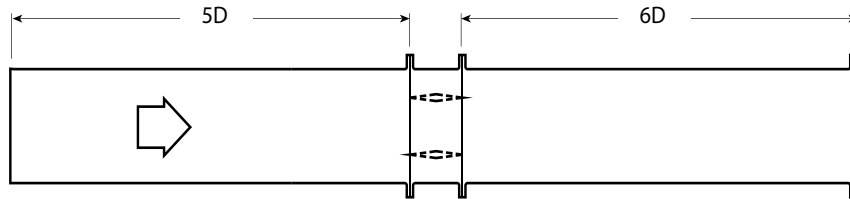
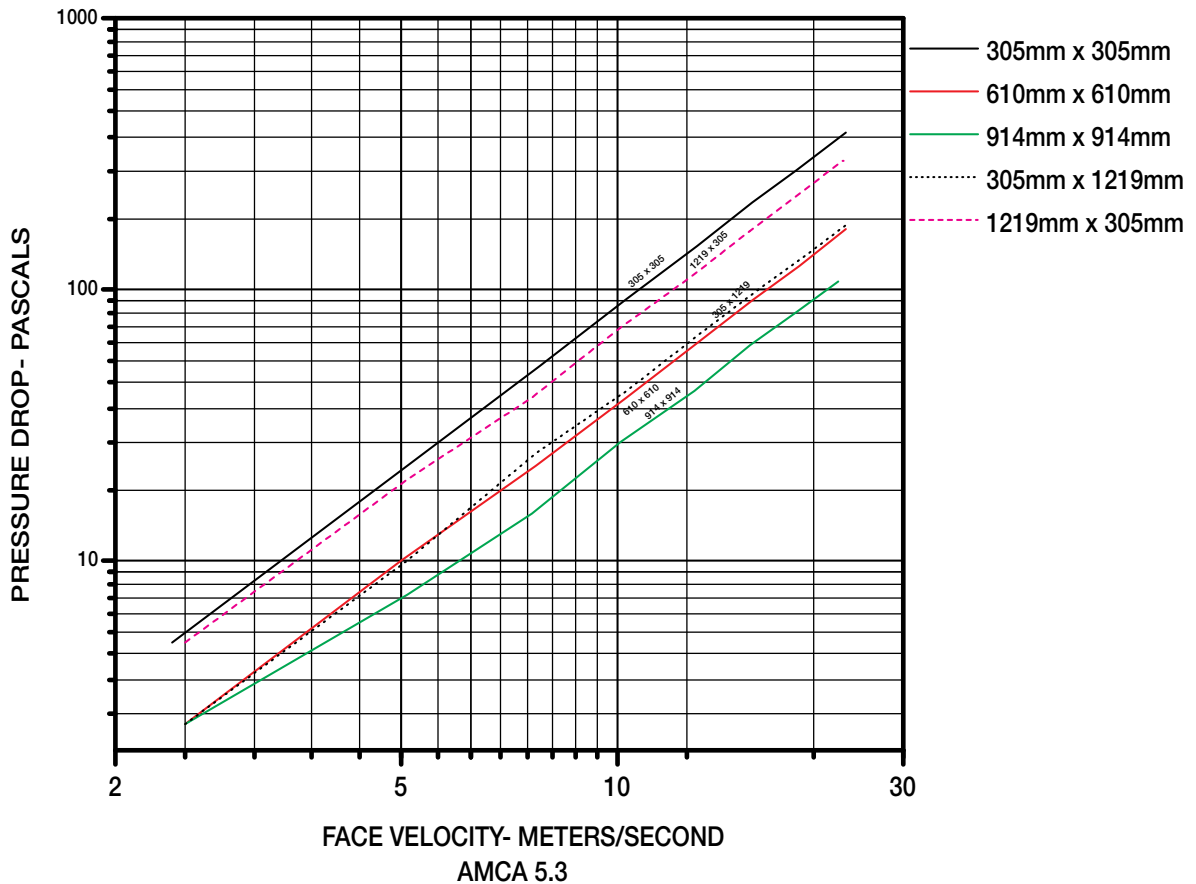

Figure 5.3

### VELOCITY VS. PRESSURE DROP



305mm x 305mm	
Velocity (m/s)	Pressure Drop (Pa)
2.4	5
5.1	22
7.8	52
10.3	92
12.9	145
15.4	209
17.7	274
20.8	379

610mm x 610mm	
Velocity (m/s)	Pressure Drop (Pa)
2.5	3
5	10
7.7	22
10.3	40
12.8	62
15.5	92
17.9	122
20.8	167

914mm x 914mm	
Velocity (m/s)	Pressure Drop (Pa)
2.5	3
5.1	8
7.6	15
10.1	27
12.8	42
15.3	62
17.7	82
20.3	107

305mm x 1219mm	
Velocity (m/s)	Pressure Drop (Pa)
2.5	3
5.1	10
7.7	25
10.3	42
12.9	67
15.7	100
18.7	140
20.9	174

1219mm x 305mm	
Velocity (m/s)	Pressure Drop (Pa)
2.5	5
5.1	20
7.6	40
10.1	72
12.7	112
15.3	164
18	227
20.6	299



Greenheck Kunshan Co. Ltd. and Greenheck Fan Corporation certifies that the model FSD-M211 shown herein is licensed to bear the AMCA Seal. The ratings shown are based on tests and procedures performed in accordance with AMCA Publication 511 and comply with the requirements of the AMCA Certified Ratings Programs. The AMCA Certified Ratings Seal applies to air performance ratings only.

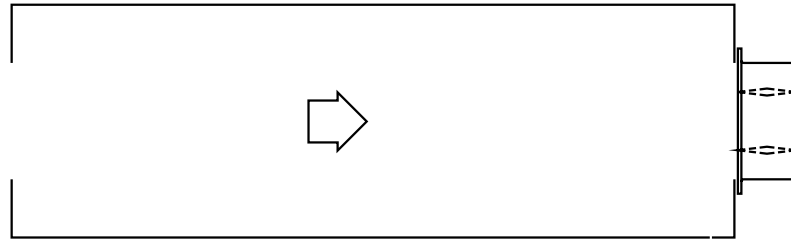

VELOCITY VS. PRESSURE DROP

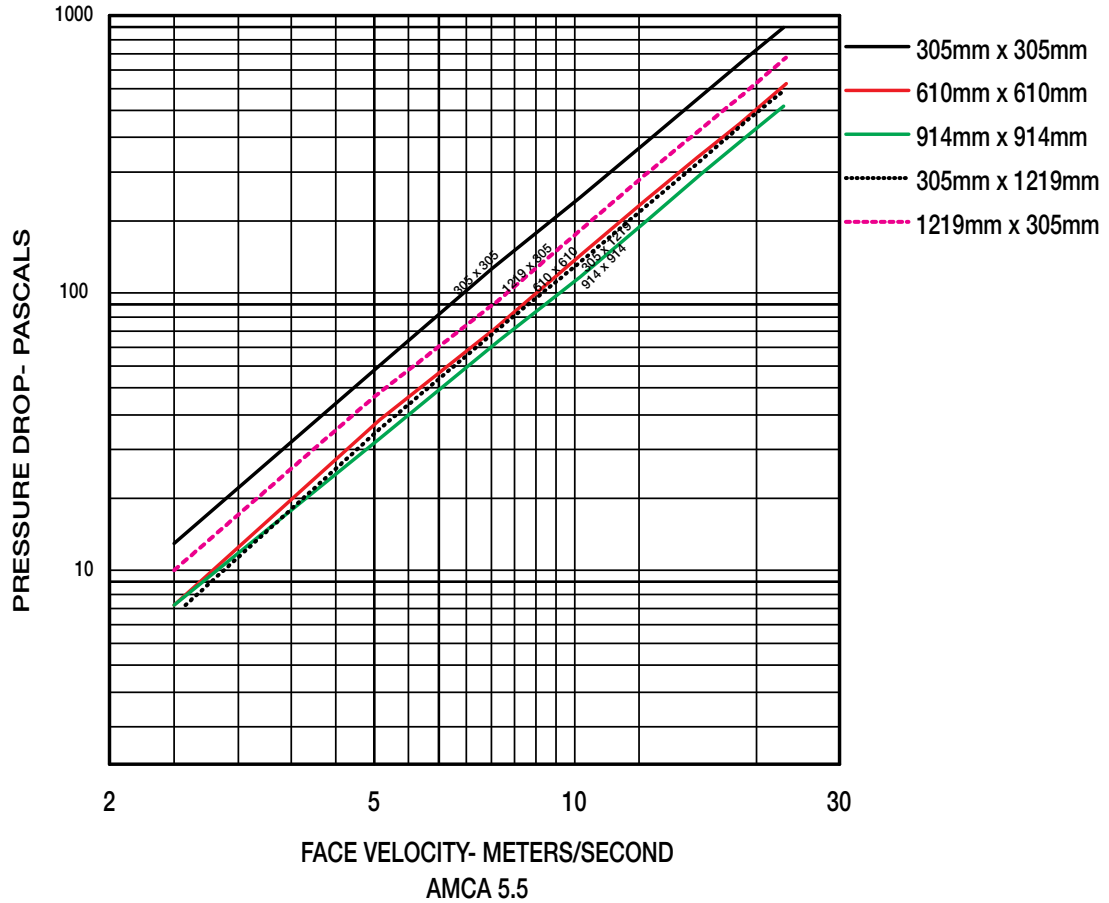

305mm x 305mm	
Velocity (m/s)	Pressure Drop (Pa)
2.5	13
5	55
7.5	122
10.2	222
12.7	349
15.4	508
17.9	688
20.6	907

610mm x 610mm	
Velocity (m/s)	Pressure Drop (Pa)
2.5	8
5	35
7.6	75
10.3	140
12.8	217
15.3	309
17.7	409
20.8	568

914mm x 914mm	
Velocity (m/s)	Pressure Drop (Pa)
2.5	8
5.1	30
7.7	67
10.2	115
12.9	184
15.5	269
18.1	354
20.6	471

305mm x 1219mm	
Velocity (m/s)	Pressure Drop (Pa)
2.6	8
5.1	32
7.7	75
10.2	130
12.7	202
15.5	301
18.1	416
20.6	536

1219mm x 305mm	
Velocity (m/s)	Pressure Drop (Pa)
2.5	1
5	42
7.7	95
10.3	172
12.7	264
15.3	381
17.9	521
20.8	707



Greenheck Kunshan Co. Ltd. and Greenheck Fan Corporation certifies that the model FSD-M211 shown herein is licensed to bear the AMCA Seal. The ratings shown are based on tests and procedures performed in accordance with AMCA Publication 511 and comply with the requirements of the AMCA Certified Ratings Programs. The AMCA Certified Ratings Seal applies to air performance ratings only.

# Damper Sizing Information

The following figures show maximum damper section size.

Single Section

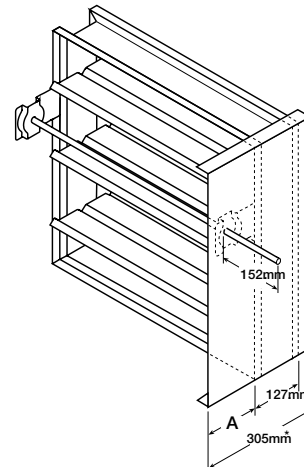
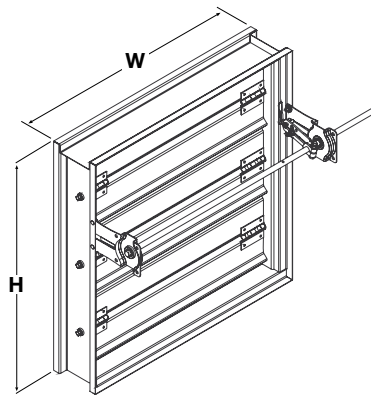

## Damper Sleeve Dimensional Data

The drawings below and corresponding table show the position of the FSD-M211 damper when mounted in a factory sleeve. The standard mounting locations provide enough space for the mounting of actuators, controls and allow space for installation of retaining angles and duct connections.

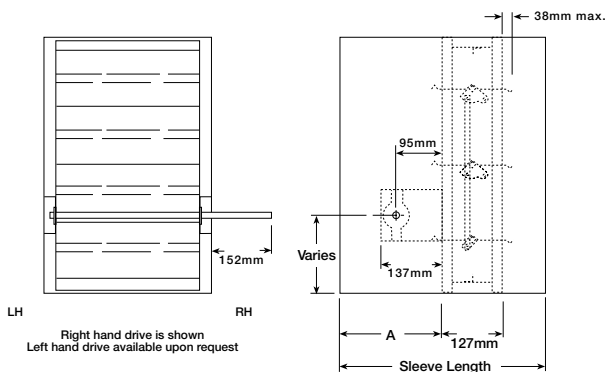

The "A" dimension is the location of the damper mounted in a factory sleeve. The table below shows the Standard, Minimum, and Maximum "A" dimensions.

in. (mm)	"A" Dimension	
	Standard	Maximum
All Dampers*	7 3/16 (183)	12 (305)
When H is 11 in. (279mm) or less with OCI, RRL, or TOR	12 (305)	12 (305)

\*With the exception of dampers 10 in. high (254mm) or less.  
NOTE: Entire damper frame is not required to be installed within the wall. The damper blades, when closed should be contained within the wall.

## Specifications

Combination Fire Smoke Dampers meeting the following specifications shall be furnished and installed where shown on plans and/or as described in schedules. Dampers shall meet the requirements of NFPA 80, 90A, 92A, 92B, 101 & 105 and further shall be tested, rated and labeled in accordance with the latest edition of UL Standards 555 and 555S. Dampers shall have a UL555 fire rating of 1½ hours and be of low leakage design qualified to UL 555S Leakage Class I.

Each damper/actuator combination shall have a UL555S elevated temperature rating of 121°C minimum and shall be operational and dynamic rated to operate at maximum design air flow at its installed location. Each damper shall be supplied with an appropriate actuator installed by the damper manufacturer at the time of damper fabrication. Damper actuator shall be (specifier select one of the following) electric type for 24 or 230 volt operation.

Damper blades shall be 1.5mm galvanized steel 3V type with three longitudinal grooves for reinforcement. Damper frame shall be galvanized steel formed into a structural hat channel shape with reinforced corners. Bearings shall be sintered bronze sleeve type rotating in extruded holes in the damper frame. Blade edge seals

shall be silicone rubber designed to inflate and provide a tighter seal against leakage as pressure on either side of the damper increases. Jamb seals shall be stainless steel compression type. Blades shall be completely symmetrical relative to their axle pivot point, presenting identical resistance to airflow in either direction or pressure on either side of the damper.

The Damper Manufacturer's submittal data shall certify all air performance pressure drop data is licensed in accordance with the AMCA Certified Ratings Program for Test Figures 5.2, 5.3, and 5.5. Damper air performance data shall be developed in accordance with the latest edition of AMCA Standard 500-D. Dampers shall be labeled with the AMCA Air Performance Seal.

Damper must be rated for mounting vertically (with blades running horizontal) or horizontally and be UL 555S rated for leakage and airflow in either direction through the damper. Each damper shall be supplied with a 74°C RRL.

The basis of design is Greenheck Model FSD-M211.



No. 1188 Pengqing Road • Huaqiao Town • Kunshan, Jiangsu China 215332  
Tel: 86.512.5736-6866 • Fax: 86.512.5737-8633

Copyright © 2010 Greenheck Fan Corporation  
FSD-M211 Rev. 8 November 2010