

Installation, Operation and Maintenance Manual

Please read and save these instructions. Read carefully before attempting to assemble, install, operate or maintain the product described. Protect yourself and others by observing all safety information. Failure to comply with instructions could result in personal injury and/or property damage! Retain instructions for future reference.

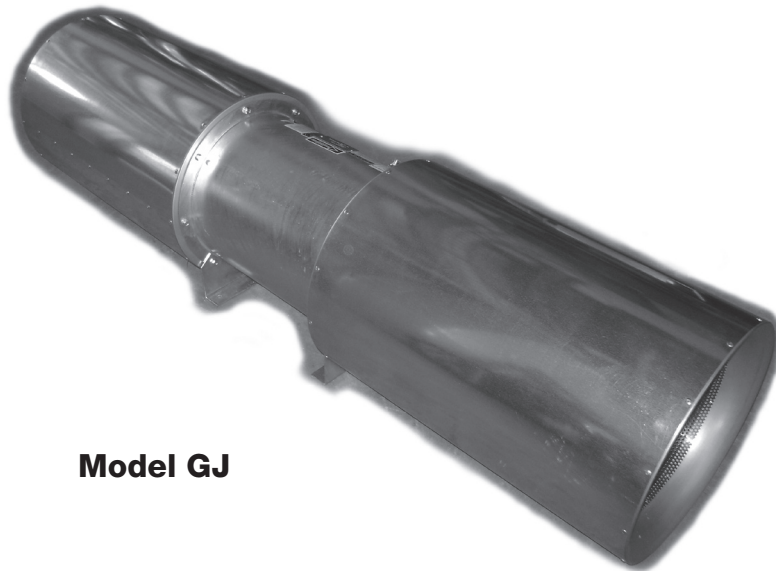

Model GJ

General Safety Information

Only qualified personnel should install this fan. Personnel should have a clear understanding of these instructions and should be aware of general safety precautions. Improper installation can result in electric shock, possible injury due to coming in contact with moving parts, as well as other potential hazards. Other considerations may be required if high winds or seismic activity are present. If more information is needed, contact a licensed professional engineer before moving forward.

DANGER

Always disconnect power before working on or near a fan. Lock and tag the disconnect switch or breaker to prevent accidental power up.

CAUTION

When servicing the fan, motor may be hot enough to cause pain or injury. Allow motor to cool before servicing.

CAUTION

Precaution should be taken in explosive atmospheres.

1. Follow all local electrical and safety codes.
2. The rotation of the propeller is critical. It must be free to rotate without striking or rubbing any stationary objects.
3. Motor must be securely and adequately grounded.
4. Do not change the blade pitch or motor without consulting the factory. Adjustments to fan speed and blade pitch significantly affects motor load and fan performance. If the blade pitch is changed, the motor current should be checked to make sure it is not exceeding the motor nameplate amps.
5. Do not allow the power cable to kink or come in contact with oil, grease, hot surfaces or chemicals. Replace cord immediately if damaged.
6. Verify that the power source is compatible with the equipment.

Receiving

Upon receiving the product check to make sure all items are accounted for by referencing the bill of lading. Inspect each crate for shipping damage before accepting delivery. Notify the carrier if any damage is noticed. The carrier will make notification on the delivery receipt acknowledging any damage to the product. All damage should be noted on all the copies of the bill of lading which is countersigned by the delivering carrier. A Carrier Inspection Report should be filled out by the carrier upon arrival and the Traffic Department. If damaged upon arrival, file claim with carrier. Any physical damage to the unit after acceptance is not the responsibility of Greenheck Kunshan Company Ltd.

Unpacking

Verify that all required parts and the correct quantity of each item have been received. If any items are missing, report shortages to your local representative and arrange to obtain missing parts. Sometimes it is not possible that all items for the unit be shipped together due to availability of transportation and container space. Confirmation of shipment(s) must be limited to only items on the bill of lading.

Handling

Handle in such a manner as to keep from scratching or chipping the coating. Damaged finish may reduce the ability of the fan to resist corrosion.

Fans are to be lifted using a minimum of four (4) points on the fan housing or attach two suitable chains / straps around the entire fan housing and one near each silencer mounting flange. For lifting unassembled, attach suitably sized chains or lifting straps to two locations on the inlet and outlet flanges.

NOTE

Do not attach straps or lift the fan by the silencer.

Storage

Fans are protected against damage during shipment. If the unit cannot be installed and operated immediately, precautions need to be taken to prevent deterioration of the unit during storage. The user assumes responsibility of the fan and accessories while in storage. The manufacturer will not be responsible for damage during storage. Cover ends of the silencers until building commissioning to prevent dust buildup inside the silencers. The following suggestions are provided solely as a convenience to the user.

INDOOR

The ideal environment for the storage of fans and accessories is indoors, above grade, in a low humidity atmosphere which is sealed to prevent the entry of blowing dust, rain or snow. Temperatures should be evenly maintained between -1°C (30°F) and 43°C (110°F) (wide temperature swings may cause condensation and “sweating” of metal parts).

All accessories must be stored indoors in a clean, dry atmosphere.

Remove any accumulations of dirt, water, ice, or snow and wipe dry before moving to indoor storage. To avoid “sweating” of metal parts allow cold parts to reach room temperature. To dry parts and packages use a portable electric heater to get rid of any moisture buildup. Leave coverings loose to permit air circulation and to allow for periodic inspection.

The unit should be stored at least 90 millimeters off the floor on wooden blocks covered with moisture proof paper or polyethylene sheathing. Aisles between parts and along all walls should be provided to permit air circulation and space for inspection.

The propeller and motor should be rotated by hand every 2 to 3 months to lubricate the motor bearings. For fans stored in a humid, dusty or corrosive atmosphere, rotate the fan propeller every month to lubricate the motor bearings.

OUTDOOR

Roads or aisles for portable cranes and hauling equipment are needed.

The fan should be placed on a level surface to prevent water from leaking into the fan. The fan should be elevated adequately so that it is above water and snow levels and has enough blocking to prevent it from settling into soft ground. Locate parts far enough apart to permit air circulation, sunlight, and space for periodic inspection. To minimize water accumulation, place all fan parts on blocking supports so that rain water will run off.

A tarp or some other waterproof cover must be used to cover the unit. Failure to cover the unit could lead to water damage of the acoustic insulation.

Inspection and Maintenance during Storage

While in storage, inspect fans once per month. Keep a record of inspection and maintenance performed.

If moisture or dirt accumulations are found on parts, the source should be located and eliminated. At each inspection, rotate the propeller by hand ten to fifteen revolutions to distribute lubricant in motor bearings. If coating deterioration begins, consideration should be given to touch-up or repainting. Fans with special coatings may require special techniques for touch-up or repair.

Machined parts coated with rust preventive should be restored to good condition promptly if signs of rust occur. Immediately remove the original rust preventive coating with petroleum solvent and clean with lint-free cloths. Polish any remaining rust from surface with crocus cloth or fine emery paper and oil. Do not destroy the continuity of the surfaces. Wipe clean thoroughly with Tectyl® 506 (Ashland Inc.) or the equivalent. For hard to reach internal surfaces or for occasional use, consider using Tectyl® 511M Rust Preventive or WD-40® or the equivalent.

REMOVING FROM STORAGE

As fans are removed from storage to be installed in their final location, they should be protected and maintained in a similar fashion until the fan equipment goes into operation.

Prior to fully assembling and installing the fan and system components, inspect the fan assembly to make sure it is in working order.

1. Check all fasteners, set screws, propeller, motor base and accessories for tightness.
2. Rotate the propeller by hand and assure no parts are rubbing.
3. Ensure proper propeller clearance and alignment around the entire housing. Adjust the motor plate accordingly to achieve this clearance.

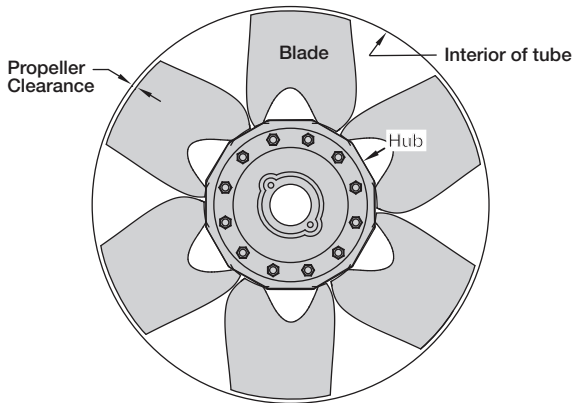

Recommended Propeller Clearance	
Unit Size	Minimum Clearance
31	3.2 mm
36	3.2 mm
41	3.2 mm

Typical Installations

The example shown below is installed using standard mounting brackets. Before beginning installation, reference the airflow direction as indicated by the direction decal attached to the fan.

Decals

This is the label for a model GJ-AU.

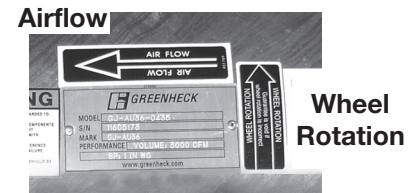

NOTE

The airflow for GJ-AB units are bidirectional and the airflow for the GJ-AU unit is unidirectional.

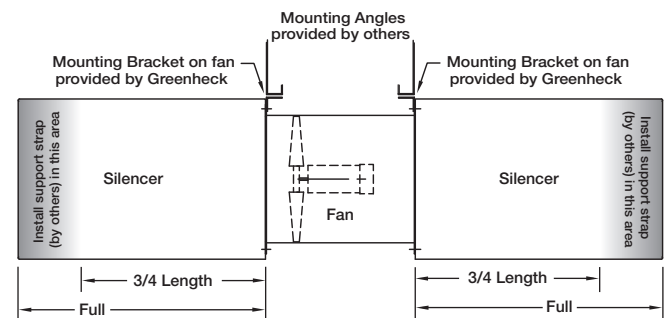

Mounting Pattern			
Unit Size	A	B	Ø
31	325	261	12
36	376	312	12
41	427	363	12

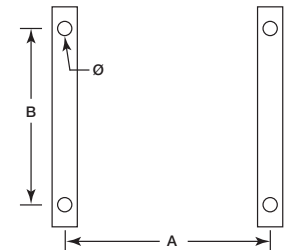

All dimensions are in millimeters.

Fan Mounting

The fan should be mounted either rigidly or through the use of vibration isolators. If vibration isolators are used, consideration should be given to ensure the safety of the installation. One method of ensuring safety is through the use of a drop rod that would 'catch' the fan if the isolator were to fail during normal operation or due to the excessive heat of a fire.

Silencer Installation

The fan and silencers are shipped disassembled in order to prevent freight damage. A total of sixteen bolts are provided for installing the silencers on the fan (eight bolts per silencer). Ensure that the silencer is centered on the fan housing before tightening the bolts.

Electrical Installation

Particular attention should be given when connecting power to the unit. The power cable should be installed to meet local requirements for high temperature operation. The power cable should be capable of meeting, as a minimum, the time and temperature applications which the fan is capable of.

Operation

Before electrical connections are made, the supply voltage, phase and ampere capacity must be checked for compatibility with the fan motor. In addition, the supply wiring must be properly fused and conform to local and national electrical codes.

The supply wires are then connected to an **optional** safety disconnect switch, to the **optional** wiring pigtail, or directly to the motor junction box.

Start-Up Checks

1. Check all fasteners for tightness. Fasteners may come loose during transit or handling at the jobsite. This includes motor bolts, mounting brackets, and bushing bolts attaching the propeller to the motor shaft.
2. Propeller rotation should be in the same direction as the rotation decal affixed to the unit. For 3-phase installations, fan rotation can be reversed by simply interchanging any two of the three electrical leads.

Field Performance Adjustments

The performance of a GJ fan can be adjusted through the use of a Variable Frequency Drive (VFD) or adjusting the fan pitch.

NOTE

Any change—increase or decrease—in fan speed (RPM) or blade pitch can represent a substantial increase in power required from the motor.

Check motor load amperage and compare to nameplate rating when changing the fan speed or blade pitch.

Torque Specifications for Bushings and Propeller Bolts

	AU	AB
Bushing Bolts/ Set Screw	12.2 N-m	10.0 N-m
Propeller Bolts	9.5 N-m	9.5 N-m

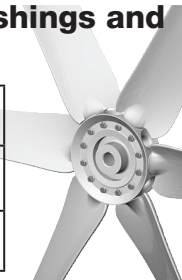

Adjusting Performance with a Variable Frequency Drive

Before wiring a Variable Frequency Drive (VFD), determine that the motor is compatible with this type of equipment. Connecting a VFD to a non-compatible motor may reduce the life of the motor. Additionally, it is important to properly ground fans being wired with a VFD. For more information on these subjects, refer to Greenheck document “Are Bearing Currents Causing Your Motor Failures?” located at www.greenheck.com. Click on Application Info, then on Product Application Articles, and use the keyword “VFD”. Greenheck is not responsible for improper wiring of a VFD or for potential motor damage as a result of operating a fan over its maximum operating frequency.

Adjusting Performance through Blade Pitch Adjustments

The blade pitch can be adjusted without removing the propeller from the fan casing. Steps to adjust the blade pitch are as follows:

1. Determine the new blade pitch required with your local Greenheck representative. Verify that the motor has sufficient capacity to handle the new power requirements.
2. Disconnect and lockout all power to the fan to prevent accidental start-up.
3. Gain access to the propeller side of the fan. This will require removing the silencer from the inlet of the fan.
4. Loosen the blades to the point where they can be rotated in the hub. Hub and blade fastening vary by fan size. Do NOT pound on the blades to adjust the pitch. They should be snug, but movable by hand.
5. Use the blade pitch protractor found on Greenheck’s Web site (www.greenheck.com) to adjust the pitch. Follow the directions stated on the guide for determining blade pitch.
6. Adjust one blade to the desired pitch angle and remove the protractor sheet.
7. Use a marker to trace the profile of the blade on the fan housing.
8. Adjust the remaining blades to the traced profile.
9. Retighten the hub to the torque specifications detailed in the Torque Specifications for Bushing and Propeller Bolts section. (See column to the left.)
10. Reinstall the fan and/or the silencer.
11. Review the Operation and Start-Up procedures.
12. After start-up, make a final check of the fan amps to ensure the motor is not overloaded.

Maintenance

WARNING

Disconnect and secure to the “Off” position all electrical power to the fan prior to inspection or servicing. Failure to comply with this safety precaution could result in serious injury or death.

Once the unit has been put into operation, a routine maintenance schedule should be set up to accomplish the following:

1. Lubrication of the motor.
2. Propeller, housing and bolts on the entire fan should be checked for tightness.
3. Any dirt accumulation on the propeller or in the housing should be removed to prevent unbalance and possible damage.
4. Inspection of fan propeller and housing looking for fatigue, corrosion or wear.

Motors

Motor maintenance is generally limited to cleaning and lubrication. Cleaning should be limited to exterior surfaces only. Removing dust and grease buildup on the motor housing assists proper motor cooling. Never wash down the motor with high pressure spray.

CAUTION

Do not allow water or solvents to enter the motor or bearings. Under no circumstances should motors or bearings be sprayed with steam, water or solvents.

Motors on high temperature rated GJ models are supplied with grease fittings which have been factory extended to the outside of the fan housing. These motors should be greased in accordance with the manufacturer’s recommendations. In the event that these recommendations are not available, use the schedule provided.

Greasing of motor bearings is only required when fittings are provided. Motors supplied with grease fittings should be greased in accordance with the manufacturer’s recommendations.

A hand held grease gun filled with Shell Albida HD2 grease should be used. This grease is rated for temperatures of -20° to 50°C at normal operation. High temperature operation for limited periods is also acceptable.

Recommended Lubrication Schedule

Frame Size	Lubrication Frequency (hours)		Lubrication Amount (grams)
	2 Pole	4 Pole	
80	15,000	15,000	3.8
90	14,000	15,000	4.0
100	12,500	15,000	6.0

Infrequent Use

Infrequent use is defined as a fan that is used less than once per month or is used in emergency situations only.

The fan should be run at least four hours every month to ensure adequate lubrication in the motor bearings. Ideally this would be two hours every other week.

Fasteners and Set Screws

A periodic inspection should include checking all fasteners and bolts for tightness. Particular attention should be paid to the bushing attaching the propeller to the motor shaft and the motor to its mounting fixture.

Removal of Dust and Dirt

Dirt clogs the cooling openings on the motor housing, contaminates bearing lubricant and collects on the propeller causing severe imbalance if left unchecked. The exterior surface of the motor and propeller should be thoroughly cleaned periodically. Use caution and do allow water or solvents to enter the motor. Under no circumstances should motors be sprayed with steam or water.

Troubleshooting

Problem	Cause	Corrective Action
Excessive Noise	Propeller Rubbing Housing	Adjust motor plate. Tighten motor plate after centering propeller in housing.
	Bearings	Replace defective bearing(s). Lubricate bearings. Tighten collars and fasteners.
	Propeller Unbalance	Clean all dirt off propeller. Check propeller balance, rebalance in-place if necessary.
Volume Too Low	Fan	Check propeller for correct rotation. Check blade pitch.
Excessive Power Consumption High Horsepower	Fan	Check blade pitch.
Fan Doesn't Operate	Electrical Supply	Check fuses/circuit breakers. Check for switches turned off or disconnected. Check for correct supply voltage.
	Motor	Assure motor is correct horsepower and not tripping overload protector.
Bearings Overheated	Lubrication	Check for excessive or insufficient grease in the bearing.

Maintenance Log

Date _____ Time _____ AM/PM
Notes: _____

Date _____ Time _____ AM/PM
Notes: _____

Date _____ Time _____ AM/PM
Notes: _____

Date _____ Time _____ AM/PM
Notes: _____

Date _____ Time _____ AM/PM
Notes: _____

Date _____ Time _____ AM/PM
Notes: _____

Date _____ Time _____ AM/PM
Notes: _____

Date _____ Time _____ AM/PM
Notes: _____

Date _____ Time _____ AM/PM
Notes: _____

Date _____ Time _____ AM/PM
Notes: _____

Date _____ Time _____ AM/PM
Notes: _____

Date _____ Time _____ AM/PM
Notes: _____

Date _____ Time _____ AM/PM
Notes: _____

Date _____ Time _____ AM/PM
Notes: _____



Warranty

Greenheck warrants this equipment to be free from defects in material and workmanship for a period of 18 months from the shipment date or one year from the date of installation, whichever occurs first. Any units or parts which prove defective during the warranty period will be repaired or replaced at our option when returned to our factory, transportation prepaid. Should motors furnished by Greenheck prove defective during this period, Greenheck should be informed and the motors should be returned to the nearest authorized motor service station. Greenheck will not be responsible for any removal or installation costs.

As a result of our commitment to continuous improvement, Greenheck reserves the right to change specifications without notice.

Greenheck Catalog Car Park GreenJet provides additional information describing the equipment, fan performance, available accessories, and specification data.

AMCA Publication 410-96, Safety Practices for Users and Installers of Industrial and Commercial Fans, provides additional safety information. This publication can be obtained from AMCA International, Inc. at www.amca.org.



- USA Phone: 1.715.359.6171
- Shanghai, China Phone: 86.21.5169-9698
- Beijing, China Phone: 86.10.6409-7203
- Kunshan, China Phone: 86.512.5736-6666
- Dubai, United Arab Emirates Phone: 971.4.881-1230
- Haryana, India Phone: 71.124.427-2494

E-mail: gfcinfo@greenheck.com • Web site: www.greenheck.com