

Centrifugal Fans - M41 Models BISW and AFSW

- Single-Width Backward Inclined and Airfoil Wheels



*Commercial &
Industrial Applications*

 **GREENHECK**
Building Value in Air.

BUILDING VALUE IN AIR.

March
2009

Industrial Duty Centrifugal Fans

Greenheck's airfoil and backward inclined centrifugal fans are designed to provide efficient and reliable operation for commercial and industrial applications. Our products are manufactured with state of the art laser, forming, spinning and welding equipment and endure our quality control testing to ensure trouble free start-up. Greenheck centrifugal models include industry leading design features to ensure your ventilation equipment has the latest technologies available.

Available with Greenheck Centrifugal Products

- AMCA Sound Certified Ratings Seal for both inlet and outlet sound
- AMCA Air Certified Ratings Seal
- All-Welded design construction
- Concentric mount bearings with industry's highest cataloged bearing life
- Corrosion resistant, electrostatically applied and baked powder coatings
- Both belt and direct drive configurations
- Three plane, six channel vibration analysis on all manufactured centrifugal models

AMCA licensed Sound and Air Performance can be found in Greenheck Performance Catalog: Single-Width Performance Supplement, Rev 1, March 2009



UL/cUL File #E40001
UL/cUL 705 Listed Power Ventilator

Greenheck's centrifugal products are specified to handle a variety of commercial and industrial projects. Typical applications include:

- General Supply, Return or Exhaust Systems
- Emergency Smoke Exhaust (buildings, car parks, etc.)
- Restaurant Grease Exhaust
- Stairwell Pressurization
- Process Heat Exhaust
- Filter Houses and dust collectors
- Built-up or Custom Air Handlers
- Spark Resistant Fume Exhaust
- Corrosive Fume Exhaust
- Grain Drying

Our expertise in air movement technology can assist you in improving the operational efficiency of your system.

Centrifugal Model Number Code:

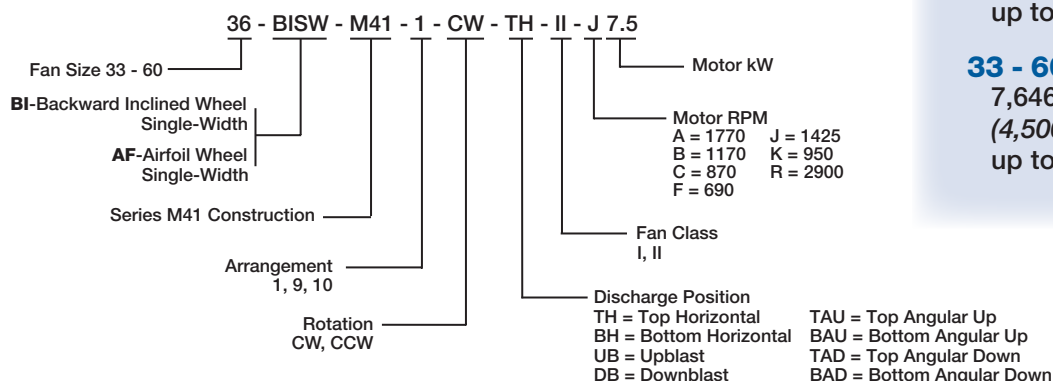

33 - 60 BISW
8,495-169,901 m³/hr
(5000 - 100,000 cfm)
up to 2242 Pa (9 in. wg)

33 - 60 AFSW
7,646 - 178,396 m³/hr
(4,500 - 105,000 cfm)
up to 2242 Pa (9 in. wg)

Series M41 Welded Housings

Greenheck Series M41 centrifugal fans are manufactured with heavy gauge edge-to-edge welded housing construction. All welded Series M41 construction is common for industrial applications and is suitable for pressures up to 5 kPa (20 inches wg). Alternative housing materials such as aluminum or stainless steel are only available with Series M41 construction by special request.



Size	Class	Housing Material	Wheel Type	Housing Type	Arrangements
33–60	I, II	Steel, Aluminum, Stainless Steel	Backward Inclined or Airfoil	Single Width	1, 9 or 10

Standard Construction Features

Housings are manufactured of laser cut and formed steel. Drive frames are manufactured with heavy gauge, welded steel. Aluminum or stainless steel construction is optional. All steel surfaces are coated with industrial gray (040) Permator™.



Fan shafts are turned and polished steel that is sized so the first critical speed is at least 25% over the maximum operating speed for each pressure class.

Steel housings and **wheels** are coated with Permator™, an electrostatically applied and baked polyester urethane. Permator is an excellent coating for interior or exterior applications. Greenheck offers a wide variety of additional protective coatings. Consult Greenheck's Product Application Guide, Performance Coatings for Ventilation Products for a complete listing of coatings and a relative resistance chart.



Wheels

Greenheck centrifugal fans have non-overloading backward inclined blades. Both our Backward Inclined (BI) and Airfoil (AF) designs operate efficiently and quietly in single-width configurations. All wheels are statically and dynamically balanced to grade G6.3 per ANSI S2.19.

	BISW	AFSW
Wheel Type		
Application	General purpose, clean air or severe environments	Clean air or fume exhaust
Temperature	Up to 538°C (1000°F)	Up to 260°C (500°F)
Construction	Steel Aluminum 316 Stainless Steel	Steel Aluminum 316 Stainless Steel

Premium Bearings

The BI and AF series of centrifugal products are manufactured with “Air Handling Quality” self aligning ball or roller pillow block bearings. Our standard bearings use concentric lock collars (no set screws) which ensure smooth operation and provide superior grip force between the bearing collar and fan shaft. All bearings are selected for a basic rating fatigue life of L(10) in excess of 80,000 hours. For more critical applications, Greenheck offers bearings with a minimum L(10) life in excess of 200,000 hours. Our bearings include zerk fittings for relubrication.



	L(10) Life	Equal to L(50) or Average Life
Industry Standard	40,000 hrs.	200,000 hrs.
Greenheck Standard	80,000 hrs.	400,000 hrs.
Greenheck Upgrade	200,000 hrs.	1,000,000 hrs.

L₍₁₀₎ life implies 90% reliability or 10% failure rate after the stated hours.
L₍₅₀₎ life implies 50% reliability or 50% failure rate after the stated hours.

Vibration Analysis

All Greenheck centrifugal products endure a complete mechanical vibration test after assembly. Our custom data acquisition system uses tri-axial accelerometers to measure the vibration in three planes at the design operating speed. A permanent record for each fan’s performance is kept on file and is available upon request.

The standard “filter-in” vibration levels attained meet the requirements of Fan Application BV-3 as defined in AMCA Standard 204-05 “Balance Quality and Vibration Levels for Fans”. Consult factory if more stringent vibration levels are necessary.



Model	Drive Type	Filter-In Vibration Limit (Rigidly Mounted)
BISW, AFSW	Belt	3.81 mm/sec-pk

Arrangement 10 – Belt Drive

Single Width *Backward Inclined or Airfoil Wheel*

- Recommended as first choice configuration for belt drive applications.
- Bearings are mounted out of the airstream.
- Motor is mounted beneath the drive frame.
- Available with a weatherhood to cover motor, drives and bearings.
- Moderate dirt and heat tolerance.
- Compact design.
- Available with heat fan packages up to 260°C (500°F)

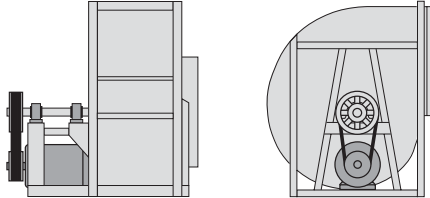

Class I, II

Arrangement 1 – Belt Drive

Single Width *Backward Inclined or Airfoil Wheel*

- Bearings are mounted out of the airstream.
- Unlimited motor size.
- Requires an isolation base (by factory) or structural pad to mount the fan and motor.
- Choice of motor positions W, X, Y or Z
- Weatherhood is not available on this arrangement. Recommend belt guard and shaft guard.
- Suitable for high temperatures or contaminated air.
- Available heat fan packages to 538°C (1000°F).

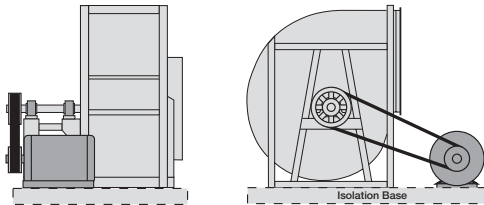

Class I, II

Arrangement 9 – Belt Drive

Single Width *Backward Inclined or Airfoil Wheel*

- Bearings are mounted out of the airstream.
- Easy access to large motors mounted on drive frame.
- Standard motor position is on the right side of the drive frame.
- Optional motor position is on the left side of the drive frame.
- Weatherhood is not available on this arrangement. Recommend belt guard and shaft guard.
- Available heat fan packages to 260°C (500°F).

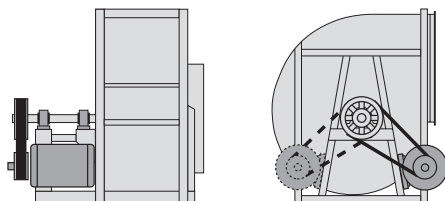

Class I, II

Discharge Positions and Rotatable Housings

All centrifugal fans are available with clockwise (CW) or counterclockwise (CCW) rotation in all standard discharge positions.

*Top Angular Down (TAD) and Bottom Angular Down (BAD) discharge positions are only available with special construction to prevent interference between the drive frame and fan discharge.

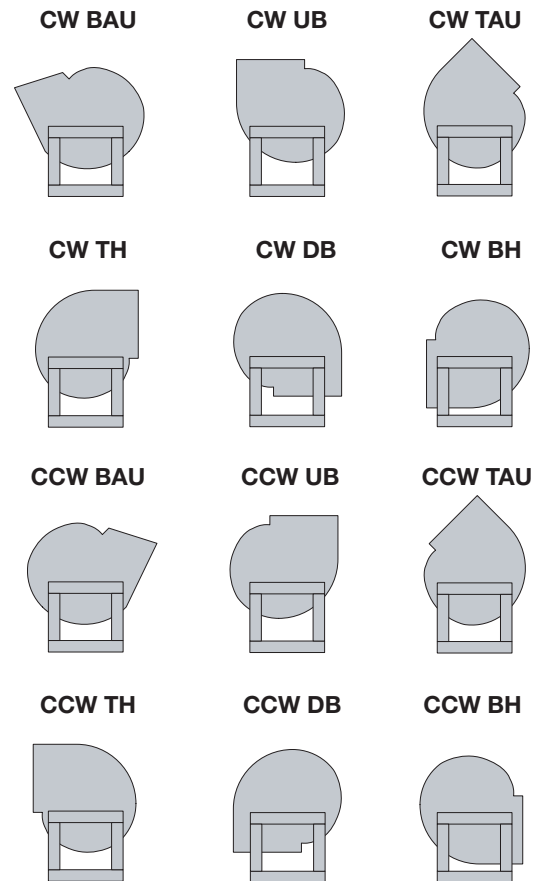

Motor Positions for Arrangement 1

Fan arrangement 1 requires a structural steel base or structural platform to support the fan and motor. The motor can be located in any of four positions around the fan shaft to ensure proper alignment. Motor positions W and Z tend to make a longer footprint from end to end. Positions X and Y tend to make a shorter but wider footprint.

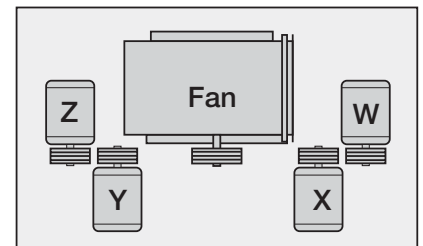

Motor position and fan rotation are determined from the drive side.

Class of Construction

Fan Class refers to a construction level designed to handle a given fan outlet velocity and pressure. As the fan performance requirements increase, the fan construction (material gauge, shaft diameter, motor size) must also increase to physically handle the new work load.

Centrifugal products are available in Class I or II, with Class I being the lightest construction and Class II having the heaviest construction and performance capacity.

A typical fan curve is shown with shaded class limits. Visit www.greenheck.com for complete centrifugal fan performance.

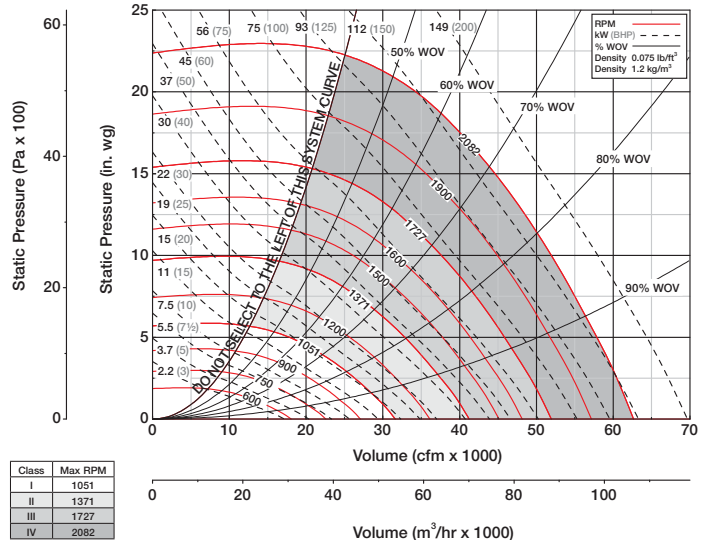

Centrifugal Accessories

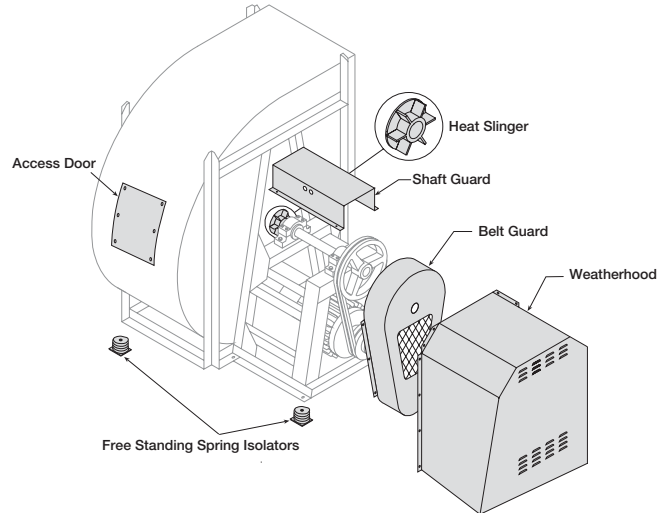
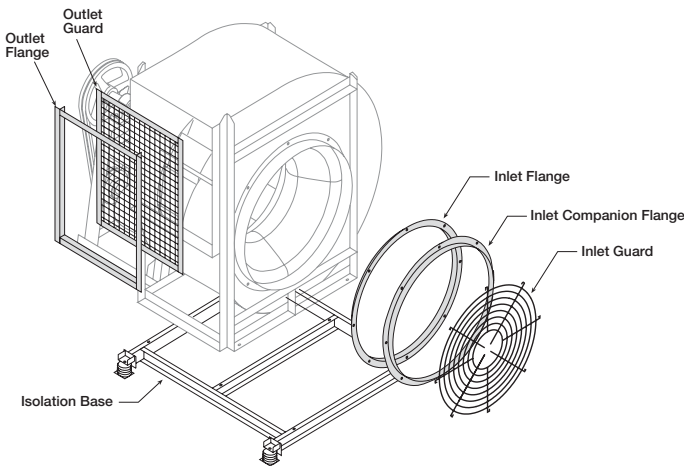

Vibration Isolators and Structural Bases

Greenheck offers a complete package of structural steel isolation bases and vibration isolators to simplify field assembly and reduce transmitted vibrations. All structural isolation bases include a motor slide base for belt adjustments. Additionally, bases are available with height saving brackets to keep the base and fan center of gravity lower to the mounting surface.

Vibration isolator options include neoprene, free standing spring, housed spring and restrained spring isolators. Seismic isolators and calculations are available on request for all centrifugal configurations.

Contact your Greenheck representative if seismic product certification is required.

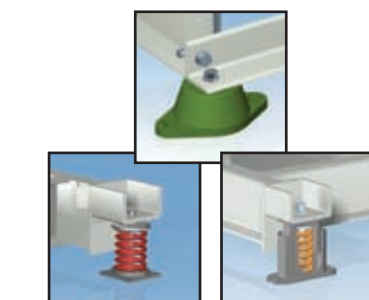
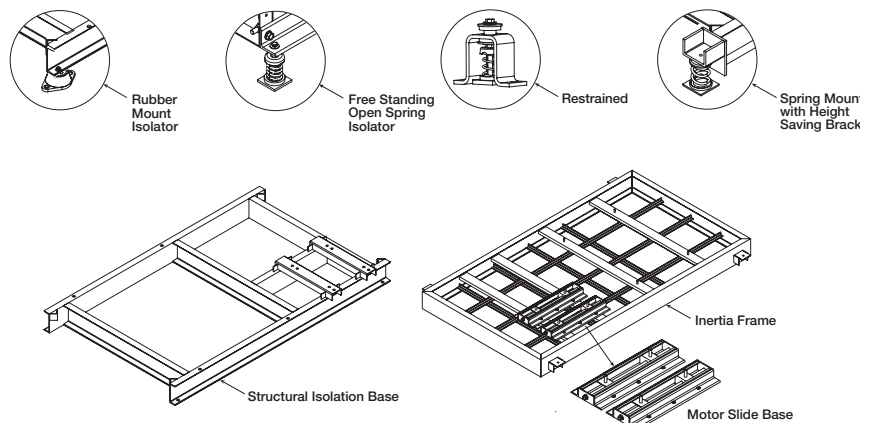

Weatherhoods for Arr. 10

Vented steel weatherhoods protect the motor and drive components from rain, moisture, dust, and dirt. Weatherhoods meet OSHA guidelines and are easily removed for service access.

Belt Guard

Belt guards are designed to allow easy access to the belts and pulleys for service. All belt guards include tachometer openings to monitor the fan speed as well as an access panel for testing belt tension. Belt guards meet OSHA guidelines.

Shaft Guard

Shaft guards are designed to cover shafts and bearings on arrangements 1 or 10 configuration. Extended lube lines are included for bearing lubrication without removal of the guard. Shaft guards meet OSHA guidelines.

Inlet and Outlet Guards

Removable inlet and outlet guards provide protection for personnel and equipment in non-ducted installations. Inlet and outlet guards meet OSHA guidelines.

Inlet and Outlet Flanges

Inlet flanges on all single width fans are pre-punched and welded to the inlet collar. Unpunched outlet flanges are standard; punched outlet flanges are optional.

Access Doors

Bolted or hinged (quick-opening) access doors provide access for cleaning or inspection. Access doors are standard on downblast discharge fans.

Companion Flanges

Punched companion inlet flanges are available for all single width fan sizes.

Drain Connection

A 25 mm threaded drain connection is located at the bottom of the fan housing to drain water that may accumulate.

Heat Slingers

The heat slinger is an aluminum cooling disc mounted on the fan shaft between the inboard bearing and the blower housing to dissipate heat conducted along the fan shaft.

Stainless Steel Shafts

Stainless steel fan shafts are available for applications where standard carbon steel shafts may exhibit excessive corrosion or heat stress.

Shaft Seals

A felt, neoprene, or ceramic shaft seal with an aluminum rub ring is available for operation at high temperatures or for exhausting contaminated air. Stuffing boxes are available upon request.

Extended Life Bearings

Extended life bearings are selected for a basic rating fatigue life (L_{10}) per ABMA Standards in excess of 200,000 hours at the maximum RPM for each pressure class. L_{10} is the life associated with 90% reliability of a bearing.

Split Pillow Block Bearings

Split pillow block bearings feature double-row roller bearings and a two-piece cast iron housing. Split pillow block bearing life is selected to exceed L_{10} life in excess of 80,000 hours.

Extended Lubrication Lines

Single width fans are available with flexible nylon tubing extending from the bearings to conveniently located grease fittings mounted on the fan drive frame (or on the fan housing if a weatherhood is supplied).

Disconnect Switches

Greenheck offers a wide selection of IEC rated disconnect switches. Switches can be factory mounted or shipped loose for field installation.

Motors

Greenheck offers a wide variety of 50 and 60 Hz motors suitable; ranging from clean air to severe duty chemical exhaust applications.



Protective Coatings

All coatings are electrostatically applied and baked powders that offer a durable, long lasting finish. For more information on our complete offering of coatings, visit www.greenheck.com and navigate to Product Application Articles. Search for [Performance Coatings for Ventilation Products](#).



Emergency Smoke Options (UL Listed)

Greenheck model BISW is available with the UL Power Ventilators for Smoke Control Systems listing which indicates it is designed and tested to exhaust heat and smoke in an emergency situation. The emergency high temperature option is suitable for the following temperatures:

Operating Temperature	Time Duration
260°C (500°F)	4 hours
300°C (572°F)	1 hour
400°C (750°F)	2 hours
538°C (1000°F)	15 minutes

Model BISW offers:



UL/cUL File #E40001
UL/cUL 705 Listed Power Ventilator

UL/cUL 762 Power Ventilators for Restaurant Exhaust
UL/cUL Power Ventilator for Smoke Control Systems

High temperature options include a heat slinger and shaft seal.

GB Emergency Smoke Evacuation

The BISW model is tested and rated for design time and temperature used in emergency heat and smoke exhaust applications according to Chinese National Standard GB/T13275 and GA211 for 280°C (536°F) for 30 minutes.

High Temperature Process Construction

The BISW and AFSW models are available in a wide variety of configurations to meet continuous high temperature exhaust requirements. Our high temperature process packages include a heat slinger, high temperature fan bearing grease, and high temperature paint for steel housed fans.

Temperature Option	Model	Arrangement	Material
121–260°C (251–500°F)	BISW, AFSW	1, 9, 10	Steel, 316 Stainless Steel
501–750°F (261–400°C)	BISW	1, 9	Steel, 316 Stainless Steel
401–538°C (751–1000°F)	BISW	1	316 Stainless Steel

Note: Aluminum construction is suitable up to 250°F (121°C)

UL Listed for Restaurant Grease Exhaust

The BISW centrifugal fan is designed for high pressure restaurant grease exhaust applications. The welded housing is suitable for indoor or outdoor mounting locations. UL 762 selections require a drain connection and access door.

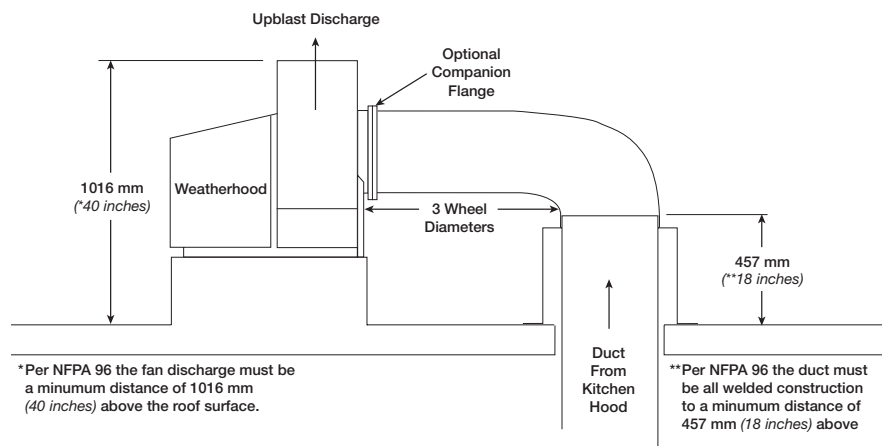

Commercial Kitchen Installation Guide

Due to high temperatures and grease-laden airstreams in commercial kitchen ventilation, system designers must be aware of governing codes and guidelines. The National Fire Protection Association (NFPA) is the primary source for many local codes for commercial kitchen ventilation systems. Local code authorities should be consulted before proceeding with any kitchen ventilation project.

- Installation must include a means for inspecting, cleaning and servicing the exhaust fan.
- Fans selected for grease removal must include a weatherhood, bolted access door, and 25 mm drain connection.
- An outlet guard is strongly recommended when the fan discharge is accessible.
- An upblast discharge is recommended.
- The fan must discharge a minimum of 1016 mm (40 inches) above the roofline and the exhaust duct must be fully welded to a minimum distance of 457 mm (18 inches) above the roof surface.
- No dampers are to be used in the system.

Alternative Materials

Greenheck offers all centrifugal models in aluminum or stainless construction as an alternative to coated steel. Aluminum construction provides advantages for applications with high moisture and various chemicals. Aluminum also reduces the weight of the fan if there are structural concerns. Stainless steel (316L) construction is used for environments subject to continuous high heat up to 538°C (1000°F) or severe corrosives. Both aluminum or stainless steel construction can be applied to the entire fan (housing, wheel, inlet cone and drive frame) or the airstream components (housing, wheel and inlet cone) only.

Spark Resistant Construction

Greenheck centrifugal fans are available with spark resistant designs suitable for applications that involve flammable particles, fumes or vapors. Spark resistant construction options adhere to guidelines defined within AMCA Standard 99-0401-86.

Spark A	All parts in contact with the airstream are constructed of nonferrous material (usually aluminum).
Spark B	The fan wheel is constructed of a nonferrous material (usually aluminum). A nonferrous (aluminum) rub ring surrounds the fan shaft where it passes through the fan housing.
Spark C	The inlet cone is constructed of nonferrous material (usually aluminum). A nonferrous (aluminum) rub ring surrounds the fan shaft where it passes through the fan housing.

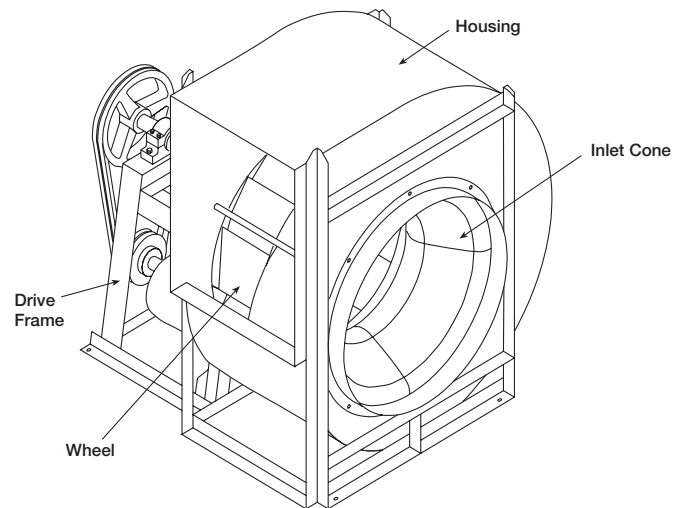

Material Availability by Model and Configuration

Construction	Model	Construction	Size	Class	Arrangement
Steel	BISW/AFSW	M41	33 – 60	I, II	1, 9, 10
Aluminum, airstream	BISW/AFSW	M41	33 – 49	I, II	1, 9, 10
316 Stainless, airstream	BISW	M41	33 – 49	I, II	1, 9, 10
Spark A	BISW/AFSW	M41	33 – 49	I, II	1, 9, 10
Spark B	BISW/AFSW	M41	33 – 49	I, II	1, 9, 10
Spark C	BISW/AFSW	M41	33 – 60	I, II	1, 9, 10

Consult factory for aluminum and stainless steel construction offering lead times.

Split Housings

Split housings can solve many space limitation problems in both retrofit and new construction situations. The standard split is horizontal, through the centerline of the fan shaft. Split housings are available on all sizes. Vertical splits are available upon request.



Selection data for centrifugal products can be found at www.greenheck.com. BSW and AFSW models can be found in the Single-Width Centrifugal Fan Performance Supplement.

Selection

The first consideration in any fan selection is the amount of air to be moved and the resistance to this air movement. Air volume requirements are established through specific codes or accepted industry standards. Once the air volume is known, system resistance can be determined by summing up the losses through the system components. Duct layout, duct size, coil, filters, dampers and fan accessories all affect system resistance. "ASHRAE Guide and Data Books" and manufacturer's data on individual system components are common sources of information available to the system designer.

In most applications, several fans may meet the required airflow and system resistance conditions. An optimum fan selection requires evaluation of alternative fan types and fan sizes, as they relate to initial cost, operating cost, available space and allowable sound levels. The relative importance of these facts varies with each system.

When deciding on a specific fan size, consider selections that allow for adjustments after installation. Avoid selecting fans that are within 10% of the maximum fan RPM or max motor horsepower capacity. If a selection is within 10% of capacity, upgrade to the next class of construction if possible. Avoid selections near the fan "stall" if there is potential variability in pressure. Operation in stall conditions will result in low fan performance and potential vibration issues. Watch for fan selections with excessive fan RPM's (above 2700 fan RPM) as these can generate higher sound levels. Select a slower running fan (typically a larger diameter wheel) if possible. Please contact your local Greenheck Representative if you need any assistance in reviewing fan selections.

Effects of Installation on Performance

Fan ratings presented in the performance tables and curves are in accordance with AMCA Standard 210 "Laboratory Methods of Testing Fans for Aerodynamic Performance Rating". The AMCA test procedure utilizes an open inlet and a straight outlet duct to assure maximum static regain.

Any installation with inlet or discharge configurations that deviate from this standard may result in reduced fan performance. Restricted or unstable flow at the fan inlet can cause pre-rotation of incoming air or uneven loading of the fan wheel yielding large system losses and increased sound levels. Free discharge or turbulent flow in the discharge ductwork will also result in system effect losses.

The examples below show system layouts and inlet and discharge configurations which can affect fan performance.

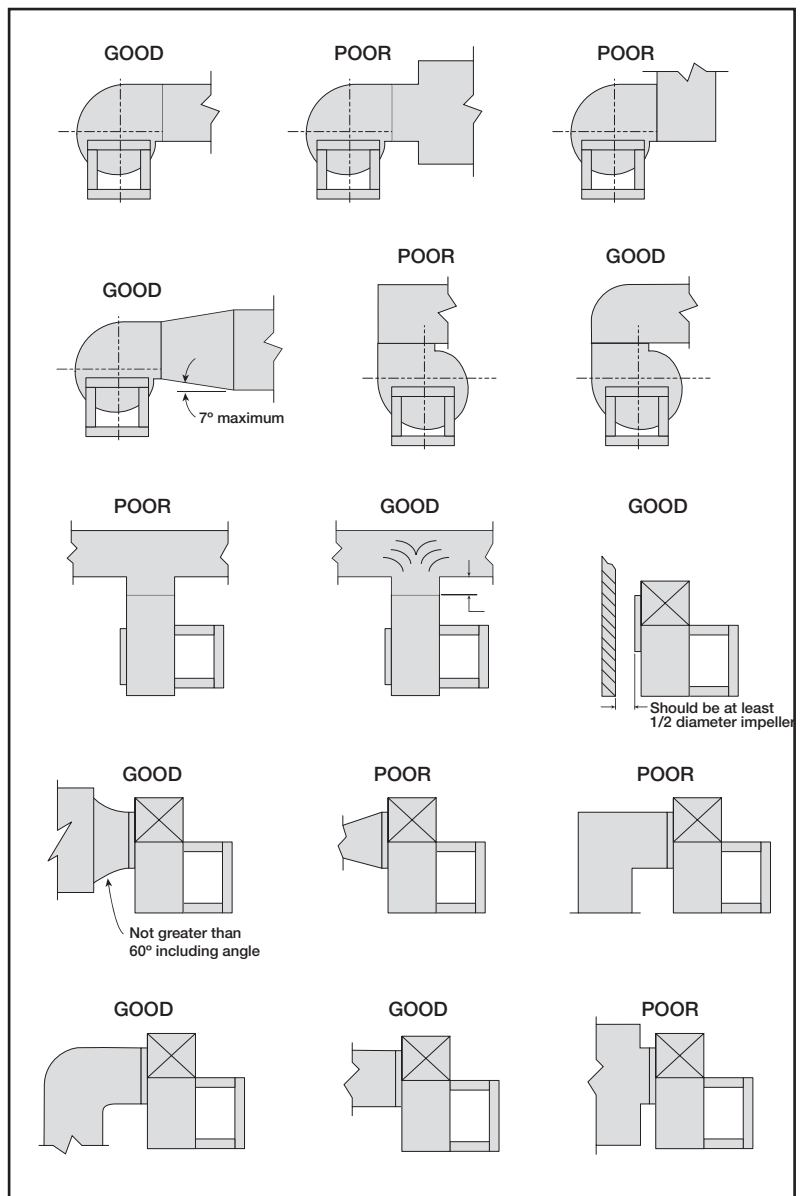

Series M41 – Class I

Fan Size	Wheel Weight		Arr. 1, 9 & 10 (BISW, AFSW)				
			Shaft Diameter (mm)	Arr. 1, 9 Weight		Arr. 10 Weight	
	BISW	AFSW		BISW	AFSW	BISW	AFSW
33	66 (146)	70 (154)	50	388 (856)	392 (864)	388 (856)	392 (864)
36	86 (189)	87 (191)	50	452 (997)	453 (999)	452 (997)	453 (999)
40	113 (249)	114 (251)	55	551 (1214)	552 (1216)	550 (1213)	551 (1215)
44	130 (287)	129 (285)	65	696 (1534)	695 (1532)	696 (1534)	695 (1532)
49	169 (373)	183 (403)	70	828 (1825)	841 (1855)	827 (1824)	841 (1854)
54	216 (477)	217 (479)	75	1017 (2241)	1017 (2243)	1016 (2239)	1017 (2241)
60	316 (697)	343 (757)	75	1234 (2720)	1261 (2780)	1234 (2717)	1260 (2777)

Weights, shown in kilograms (*pounds*), are for steel fans and do not include motors, drives or accessories. Fan weights may vary up to 5% based on the discharge position.

Series M41 – Class II

Fan Size	Wheel Weight		Arr. 1, 9 & 10 (BISW, AFSW)				
			Shaft Diameter (mm)	Arr. 1, 9 Weight		Arr. 10 Weight	
	BISW	AFSW		BISW	AFSW	BISW	AFSW
33	75 (165)	82 (180)	55	403 (889)	410 (904)	403 (889)	410 (904)
36	93 (204)	102 (224)	65	475 (1048)	484 (1068)	475 (1048)	484 (1068)
40	122 (268)	132 (291)	65	570 (1256)	580 (1279)	569 (1255)	580 (1278)
44	153 (337)	150 (331)	70	734 (1619)	732 (1613)	734 (1619)	732 (1613)
49	197 (434)	196 (432)	75	865 (1908)	865 (1906)	865 (1907)	864 (1905)
54	250 (552)	249 (549)	85	1077 (2374)	1075 (2371)	1076 (2372)	1075 (2369)
60	353 (778)	337 (744)	85	1322 (2914)	1306 (2880)	1320 (2911)	1305 (2877)

Weights, shown in kilograms (*pounds*), are for steel fans and do not include motors, drives or accessories. Fan weights may vary up to 5% based on the discharge position.

Design and Selection Support

Computer Aided Product Selection Program – CAPS

All Greenheck products are supported by the industry's best product literature, electronic media, and Computer Aided Product Selection program, (CAPS). You'll also find extensive product and Installation and Operation Manual (IOM) information on our website, www.greenheck.com.

And, of course, you can always count on the personal service and expertise of our sales representative organization. To locate your nearest Greenheck representative, visit our website at greenheck.com or call any of the phone numbers provided below.



To-Scale Drawings and Fan Specifications

To-scale CAD drawings along with detailed centrifugal specifications can be found online at www.greenheck.com or within our Computer Aided Product Selection program (CAPS).

Building Value in Air

Greenheck delivers value to mechanical engineers by helping them solve virtually any air quality challenges their clients face with a comprehensive selection of

top quality, innovative air-related equipment. We offer extra value to contractors by providing easy-to-install, competitively priced, reliable products that arrive on time.

And building owners and occupants value the energy efficiency, low maintenance and quiet dependable operation they experience long after the construction project ends.

Our Warranty

Greenheck warrants this equipment to be free from defects in material and workmanship for a period of 18 months from the shipment date or one year from the date of installation, whichever occurs first. Any units or parts which prove defective during the warranty period will be repaired or replaced at our option when returned to our factory, transportation prepaid. Should motors furnished by Greenheck prove defective during this period, Greenheck should be informed and the motors should be returned to the nearest authorized motor service station. Greenheck will not be responsible for any removal or installation costs.

As a result of our commitment to continuous improvement, Greenheck reserves the right to change specifications without notice.



- USA Phone: 1.715.359.6171
- Shanghai, China Phone: 86.21.5169-9698
- Beijing, China Phone: 86.10.6409-7203
- Kunshan, China Phone: 86.512.5736-6666 • greenheck.com

